

OCULAR



IQ PORTABLE USER MANUAL

Powered by Exploren Software

CONTENTS

Product Overview	3
Specifications	4
Safety Instructions.....	5
Screen and Buttons Overview	6
Unboxing	8
Wall Mounting Instructions - Optional.....	8
Ways to Charge	11
RFID.....	11
How to Set Up Exploren App.....	12
Download and Set Up Exploren App	12
Start/Stop Charging from Exploren	14
Offline Charging	15
Adding an RFID Card	16
Plug and Charge	17

PRODUCT OVERVIEW

The Ocular IQ Portable is a portable AC EV charger that has a built in 4G modem and full internet connectivity. The charger is OCPP compatible which means that it can be connected to an EV charging management system. Your IQ Portable has been shipped pre-configured with the Exploren Software. This enables you and your charger provider to track charging history and reimburse charging costs. The specific configuration will depend on your company needs.



No	Item
1	LCD display
2	STOP touch button
3	AMPS touch button
4	LED status indicator
5	Wall plug
6	RFID reader
7	Type 2 charging plug

SPECIFICATIONS

Model	8 Amp	32 Amps Single Phase	32 Amps Three Phase
Power			
Power Output	1.8kW	7kW	22kW
EV Charging Connector	5m Type-2 Cable		
Cable Length to Wall Plug	1.5m Type-2 Cable		
Wall Connector Plug	Standard 10 Amp plug	3 Pin 32 Amp Australian Standard plug	5 Pin 32 Amp Three phase Australian Standard plug
Input and Output Voltage	230V ± 20%		400V ± 20%
Input and Output Current	8 Amps	32 Amps	32 Amps per phase
Frequency (Hz)	50/60Hz		
User Interaction			
Display	1.54 Inch LCD Display, LED indication lights		
Charger Control Method	Mobile app, physical button, plug and charge, RFID, OCPP		
Safety			
Internal RCD	30mA Type A & 6mA DC Leakage		
RFID Reader	ISO14443 Type A cards compatible		
Electrical Protection	Over current, Short circuit, Over voltage, Under voltage, Ground fault, Lightning surge, Over temperature, Over load protection, UV Resistance		
Communication			
OCPP	1.6J		
Communication Connection	Wifi, Bluetooth, 4G		
Energy Meter	Integrated Meter		
General Data			
Operating Temperature	-30°C to +50°C in operation		
Storage Temperature	-40°C to +70°C in storage		
Working Humidity	5% - 95% relative humidity, non-condensing		
IP Performance	IP65		
Mounting	Optional wall bracket		
Dimension (H x W x D, mm)	273.1 * 93.4 * 73 mm		
Net Weight	2.7 kg	4.1 kg	5.3 kg
Certification	CE, IEC61851-1, IEC 62752, IEC 62196, IEC 60335-1 (C 30.2)		
Warranty	2 Years (Extended warranties available)		

SAFETY INSTRUCTIONS

This document contains important instructions and warnings that must be followed when installing and maintaining the Ocular IQ Portable.

WARNINGS

- Read through this entire manual before operation.
- Do NOT disassemble or modify the charger in any way.
- Only use the charger with compatible vehicles and power outlets.
- Before each charging session, ensure the charger is securely connected and grounded. This includes ensuring the threading is tightened to the power outlet for the 32A models of chargers, so that the charger cannot be accidentally unplugged.
- Ensure cables are not tangled, sharply bent, or under tension when storing or using the charger.
- ALWAYS unplug the charger before:
 - cleaning or storing the charger
 - moving the vehicle
- NEVER store or use the charger:
 - around flammable or volatile vapours or gases
 - around corrosive liquids or fumes
 - in temperatures or humidities outside the range specified on the data sheet (inc. prolonged exposure to harsh sunlight)
 - in extreme weather conditions
 - in standing water
 - near a heat source
- Do NOT use the charger when:
 - the vehicle or wall-outlet connections are wet or dirty
 - there is visible damage to the charger body, cables, or connectors
- Ensure circuit that the charger is connected to is protected by a residual current circuit breaker.
- Do not use if the charger, plug, or cable is damaged.
- Only to be used for charging compliant type-2 electric vehicles.
- Do not open or modify the charger.
- Do not use this device with an extension cord, power board or adapter.
- Please ensure the power point is inspected annually by a licenced electrician and is in good condition.

SCREEN AND BUTTONS OVERVIEW



No	Item	No	Item
1	Number of phases	9	Lifetime energy delivered
2	Status indicator	10	Session duration
3	Charging current	11	Internal temperature
4	Input voltage	12	Serial number
5	Session energy	13	4G/ Wi-Fi status
6	Charging power	14	Bluetooth status
7	OCPP status	15	Maximum charging speed
8	RFID reader status		



STATUS ICONS

There are four icons located on the bottom of the screen for 4G/ Wi-Fi, Bluetooth, OCPP server connection, and RFID reader status. Depending on the colour, they represent different meanings:

Colour	Meaning
White	The function is up and running
Green	Connection is established
Red	4G/Wi-Fi has no signal when 1 bar or less
Grey	The function is turned off

LED Status Meaning:

Colour	Meaning
Static Blue Light	Charger is offline, ready to charge
Flashing Green Light	Charger is charging
Static Green Light	Charger is online, ready to charge
Flashing Red Light	Charger is faulty



AMPS BUTTON:

This button is DISABLED when the charger is setup on Exploren.



STOP BUTTON:

Long press the STOP button to stop charging.

UNBOXING

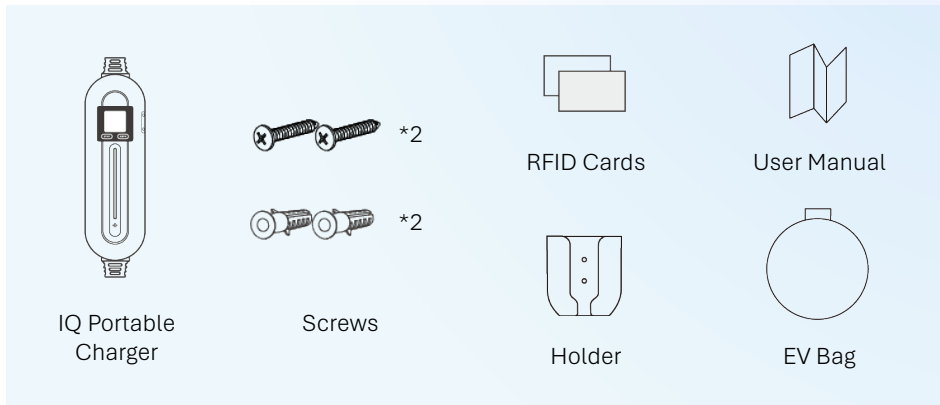

WALL MOUNTING INSTRUCTIONS – OPTIONAL:

1. Preparation

Installation Location

1. Make sure the charging cable can reach EV's charging port.
2. Make sure there's enough space to safely store the charging cable.
3. For outdoor installation, it's recommended to install under a cover for the longevity of the charger.
4. Install in a well-ventilated space. Avoid installation in tight space and near heat source.

Installation Height

1. Maximum installation height (indoor and outdoor): 1.5 m
2. Recommended installation height: 1.2 m
3. Minimum outdoor installation height: 0.6 m
4. Minimum Indoor installation height: 0.45 m

4G SIM Card Installation Guide

Your IQ Portable should have been shipped with a pre-installed SIM card. If you need to swap the SIM card please follow these instructions. If you are changing SIM card provider, additional configuration will be required. Please contact the Ocular or Exploren teams for more information on this procedure.

1. The charger uses Nano sized 4G SIM card
2. Please follow the orientation indicated in the icon next to the 4G slot to insert the card. Incorrect installation may result in failure to recognize the card or even damage the slot.

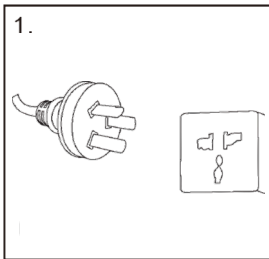

1. Ensure the device is powered off

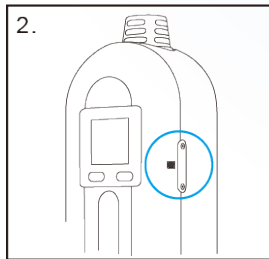

2. The SIM card location is on the top right corner of the charger

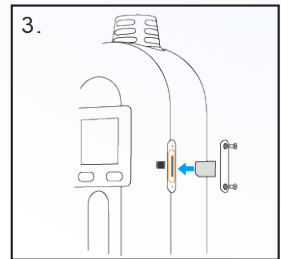

3. Take out the two screws to remove the cap, insert the SIM card with the orientation shown in the photo, you will hear a click once it's in place

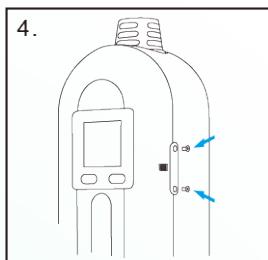

4. After inserting the SIM card, put back the cap and tighten the screws to finish the installation

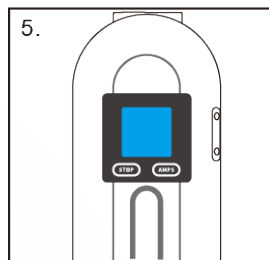

5. After installation is complete, you can power on the device

2. Wall Mount Bracket Installation Instructions

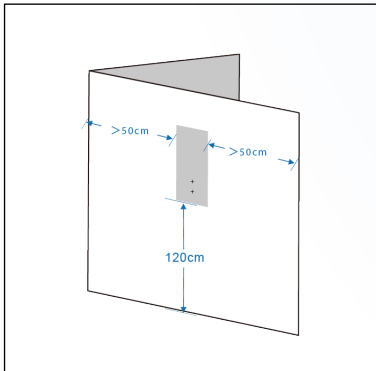

Step 1: Positioning

The bottom of the wall bracket is recommended to be 1.2 m above the ground. It is recommended the wall bracket is at least 0.5 m away from the edges of the wall. Drill according to reference paper.

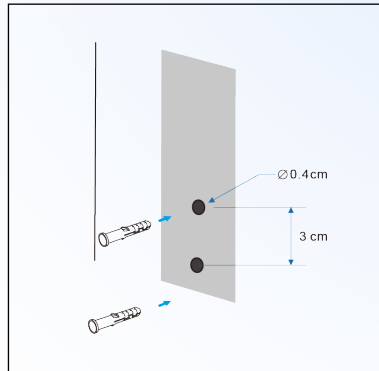

Step 2: Installing bracket

Drive the expansion bolt into the hole and secure the bracket to the wall with the included screws.

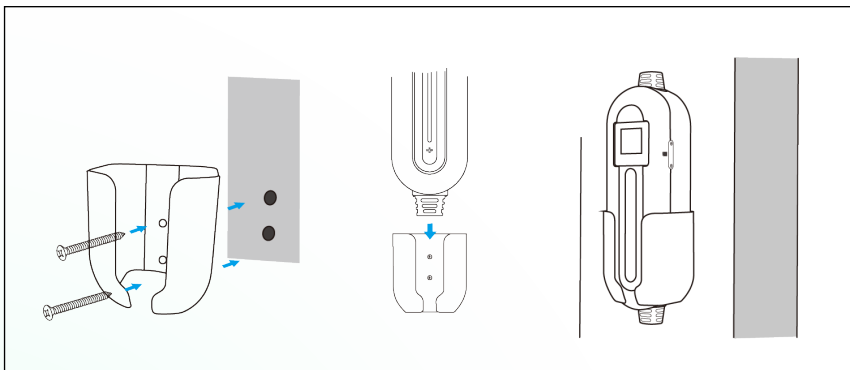

Step 3: Mount device

After the installation of the bracket, put the charger into it as shown in the photo to finish the install.

WAYS TO CHARGE WITH RFID

The two RFID cards included in the box should be pre-linked to your Exploren account, if they are not linked, please refer to the adding RFID section.

To start charging:

1. Plug the charger into the wall outlet, if it's the 7kW or 22kW version please tighten the screw collar to secure the connection and then turn on the isolator.
2. Wait for the charger to connect to internet and the OCPP server, the top right corner should show Ready if it's connected, this can take up to 2 minutes.
3. Plug the charger into the vehicle, and tap the RFID card on the RFID reader.
4. The charger will make a beeping sound, and, on the screen, it will show Starting indicating the charging has started.

To stop charging:

1. You can stop charging from:
 - a. the **vehicle**,
 - b. the **RFID** card or
 - c. the **Stop button** on the charger.

To stop with the **vehicle**, use the vehicle app or screen to unlock connector or stop charging.

To stop with the **RFID card**, simply tap the same RFID used to start charging on the RFID reader, the screen will show Stopping indicating the charging is stopping.

To stop with the **Stop button**, long press the STOP button and the screen will show Stopping.

2. After the charging has stopped, unplug the charger from the vehicle and place the rubber cap back onto the connector.
3. You can leave the unit on or remove from the wall if you wish.
4. If the charger doesn't start charging after swapping the RFID card, it means the card is not linked to your Exploren account.

HOW TO SET UP EXPLOREN APP

Download and set up Exploren app:

Exploren allows you to add a home charger to the app, giving you insight into your charger's status, your charging history, smart scheduling, and more! Follow the steps below to add a home charger to the Exploren app.

1

Download the Exploren app from the Apple Store or the Google Play Store. Search “**Exploren**” or scan one of the QR codes.

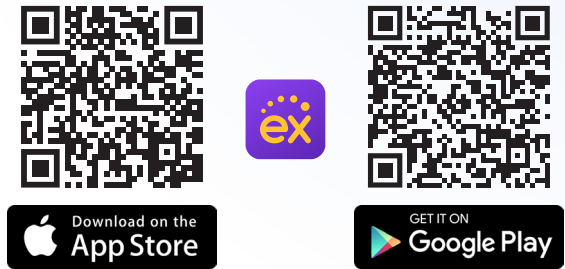

2

Navigate to the **Home** tab on the Exploren app. Tap on the far-left icon along the bottom of the app.

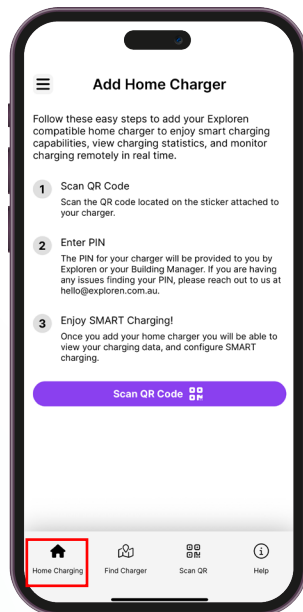

3

Tap the **Scan QR Code** button.

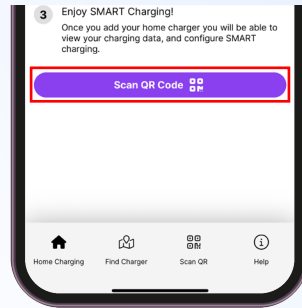

4

Scan the QR code on your EV charger, or enter the 4-digit station ID. Your charging station will have an Exploren sticker on it; it will look similar to the image.

If your charging station is missing this sticker, call us at **1300 755 087** or email us at **help@exploren.com.au**.



5

Enter the 4-digit PIN for your charger.

You should have been provided a 4-digit pin by either your fleet manager or from us at Exploren. If you're having trouble identifying the pin, call us at **1300 755 087** or email us at **help@exploren.com.au**.

6

Your charger will now be connected to the Exploren app. You can now start and stop charging sessions using the following instructions.

Start/Stop charging from Exploren:

1

To start charging through the Exploren app, first plug the charger into the wall outlet, if it's the 7kW or 22kW version, please tighten the screw collar to secure the connection and then turn on the isolator. Wait for the charger to connect to internet and the server, the Exploren app will show **Ready** once it's connected, this can take up to 2 minutes.

Please allow the unit to come online before plugging in. The unit will say **Ready**.

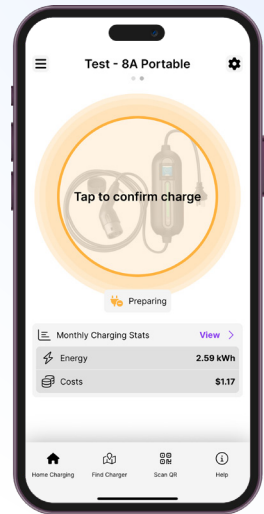

2

Once the charger is online and ready, plug the charger into the car and the Exploren app ask you to confirm the charging, tap on the charger image to start charging or via an RFID linked to your account - see RFID section.

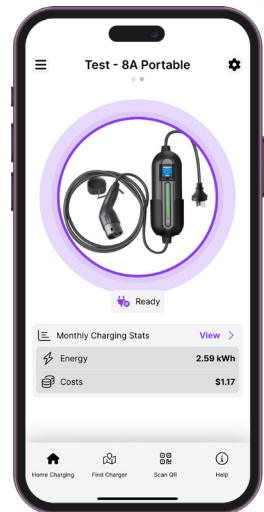

3

Once the charging started, you will see the charging speed, duration and total energy. To stop charging, press the **Stop button** on the app, you can also stop by long pressing the physical STOP button on the charger or stop from your car (check owner's manual for instructions). A summary page will show after the charging is finished.

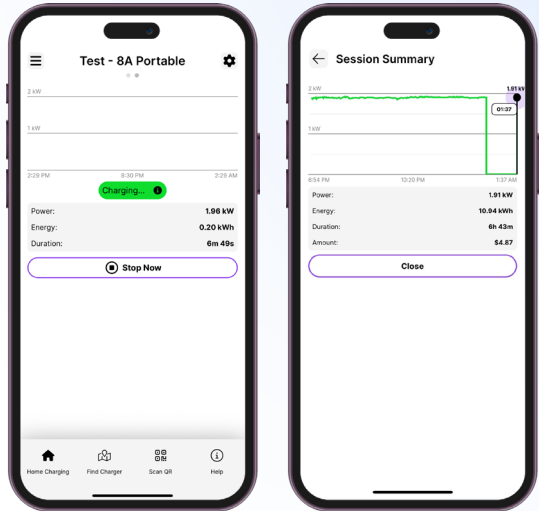

Offline charging:

In OCPP mode, if the charger goes offline, you can still charge with the RFID card associated with your account, and the offline charging records will be uploaded to the server once it is back online. Up to 50 offline charging records can be stored in the charger.

It's important to regularly check the Explore app Home section to ensure all electricity, pricing and energy data is being transmitted. If the charger is offline. Please reboot and ensure it comes back online. If unable to get the unit online. Please reach out to Exploren.

ADDING AN RFID CARD

1. Ensure your charger is plugged in, powered on, and connected to the internet. Open the Exploren app and click the menu button.
2. The menu will appear with a range of options available. Choose RFID cards.
3. Choose add RFID Tag.
4. Read the Instructions and choose Scan QR Code.
5. Scan the QR code on the Exploren sticker of the charger. You can also enter the charger ID manually. The charger ID can be found on the sticker on the side of the charger.
6. The above screen should appear. Scan your RFID tag on the Exploren Sticker within 30 seconds to complete the process.

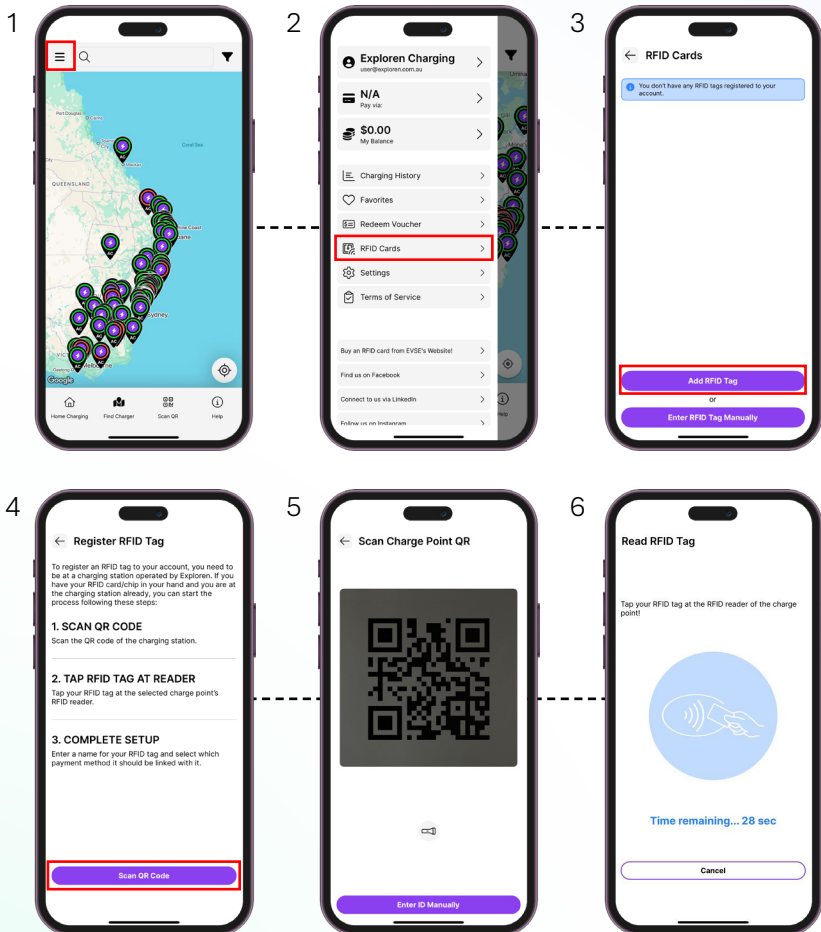

PLUG AND CHARGE

If you wish to get reimbursement for the charging, please contact your fleet manager if plug and charge is acceptable.

If the charger is set to plug and charge, you can start a charging session by simply plugging the charger into your car. To stop charging, push the STOP button on the front of the charger. You can also stop charging from your car (check car owner’s manual for instructions).

To set the charger to plug and charge on the Exploren platform, first go to the Exploren app and select the Home tab, then select the setting button on the top right corner of the screen and press “Configuration”.

Then go to “Authentication”, select “Not Required” from the drop-down menu and click “Save Changes”

