

OCULAR



IQ HOME SOLAR INSTALLATION GUIDE

IOCAH15-7T / IOCAH15-22T

Version 2.0

 ocularcharging.com.au

 sales@ocularcharging.com.au

 1300 912 650

CONTENTS

Specifications	3
Product Overview	4
Safety Instructions	5
Installation Notes and Box Contents	6
Wall Mounting	7
Internet Connection and Charger Mounting	8
CT Clamp Installation	9
Single Phase CT Installation Diagram	9
Three Phase CT Installation Diagram	10
CT Clamp Wiring	11
Internet Connection	11
Web-Interface Access and WIFI Setup	12
Accessing Charger Settings	13
Charger Configuration - CT Clamp Set Up	14
Charger Configuration - Grid Supply Set Up	15
Installation Verification	16
Connect Charger to Ocular Smart Home App	17
Appendix A - Troubleshooting	18
Appendix B - Charger Error Codes	19
Appendix C - CT Clamp Specifications	21

IMPORTANT!

Read this entire document before installing or using the charger. Failure to do so or to follow any of the instructions and warnings in this document can result in fire, electrical shock, serious injury, or death.

The charger must be installed by a qualified electrician.

The entire installation must comply with the latest AS 3000 standards.

SPECIFICATIONS

Model Number	IOCAH15-7T	IOCAH15-22T
Power		
Power Output	7.2kW (1-Phase)	22kW (3-Phase)
EV Charging Connector	5m Type-2 Cable	
Input and Output Voltage	230V ± 20%	400V ± 20%
Input and Output Current	32A max per phase	
Recommended Circuit Breaker	40A type A RCBO	
Frequency (Hz)	50/60Hz	
Current Transformers (CT) for Solar and Load Control		
CTs Included	1	3
CT Length of Signal Line	20m (Extendable up to 100m with insulated twisted pair cable)	
CT Primary Rated Current	100A max current	
CT Internal Diameter	16mm (fits max cable size 50mm ² XLPE)	
User Interaction		
Display	LED indication lights	
Charger Control Method	Mobile App, physical button, plug and charge	
Safety		
Internal RCD	30mA AC & 6mA DC Leakage	
Electrical Protection	Over current, Short circuit, Over voltage, Under voltage, Ground fault, Lightning surge, Over temperature	
Communication		
OCPP	1.6J and 2.0.1 (Firmware upgrade required)	
Internet Connection	Ethernet, Wi-Fi	
Communication Type	Modbus (TCP/IP)	
Energy Meter	Integrated Meter	
Load Control	Compatible with Ocular Load Controller or OCPP smart profiles	
General Data		
Ambient Air Temperature for Operation	-30°C to +50°C	
Ambient Air Temperature for Storage	-40°C to +70°C	
Working Humidity	5% - 95% relative humidity, non-condensing	
IP Performance	IP55	
Mounting	Wall Mount	
Dimension (H x W x D, mm)	398 * 285 * 226 mm	
Net Weight	4.5 kg	4.7 kg
Certification	CE, IEC /EN 61851-1, IEC 61008-1-A1, IEC 62955-1-A1, IEC/EN 61851-21-2, IEC 62196-2, RCM	
Warranty	2 Years (Extended warranties available)	

PRODUCT OVERVIEW



No	Item
1	Type-2 charging cable and plug
2	LED status indicator
3	Physical button
4	Plug storage recess

SAFETY INSTRUCTIONS

This document contains important instructions and warnings that must be followed when installing and maintaining the workplace pedestal charger

WARNINGS

Do not install or use the charger near flammable, explosive, harsh, or combustible materials, chemicals, or vapors.

Turn off input power at the circuit breaker before installing or maintaining.

Do not use or stop using the charger if it is defective, appears cracked, frayed, broken or otherwise damaged, or fails to operate.

Do not attempt to open, disassemble, repair, tamper with, or modify the charger. The charger is not user serviceable. Contact iocharger or authorized service provider for any repairs.

Do not touch the charger sockets with sharp metallic objects, such as wire, tools or needles.

Do not put fingers into the charger sockets.

Do not use this charger if the EV charging cable is frayed, has broken insulation, or displays any other indication of damage.

Do not use this charger if the enclosure or the EV charging connector is broken, cracked, open, or shows any other indication of damage.

Ferrules must be used to ensure warranty is valid

CAUTIONS

The charger should be installed only by a qualified approved technician.

Make sure that the materials used and the installation procedures follow local building codes and safety standards.

Incorrect installation and testing of the charger could potentially damage either the vehicle's Battery and/or the charger itself. Any resulting damage is excluded from the warranty for both the vehicle and the charger.

Do not operate the charger in temperatures outside its operating range of -30°C to +50 °C.

Ensure that the EV charging cable is positioned properly to the charging sockets. Do not use cleaning solvents to clean any of the charger's components.

NOTES BEFORE INSTALLATION

The charger should be protected by an external Residual Current Device (RCD) to be installed in the upstream circuit which complies with the following:

- Type-A Rated residual operating current not exceeding 30 mA
- Required as per Appendix P, AS 3000:2018 Australia Standard for EV charging stations.

Recommended (Note installation requirements are site specific and may vary):

- 40A 30mA Type A RCBO
- Isolation Switch close to the charger
- 10mm² 2C (or 4C) + E Cabling

TOOLS REQUIRED

- Philips #2 screwdriver
- Electric drill
- Laptop or mobile device

BOX CONTENTS

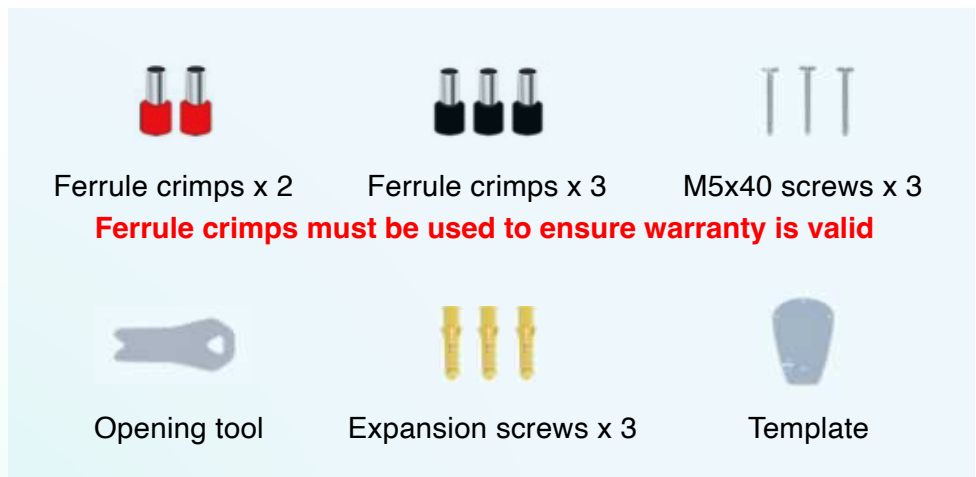

CT clamps

- 1 clamp come with the single phase model
- 3 clamps come with the three phase model

Please note: The provided CT clamp cable is 20 meters long. Charger must be placed within 20m of the incoming supply. Fits 16mm diameter cabling up to 100A max current.

WALL MOUNTING AND WIRING

1. Using the enclosed template on the wall and mark all the mounting holes required. Drill holes where the fixing points are marked.

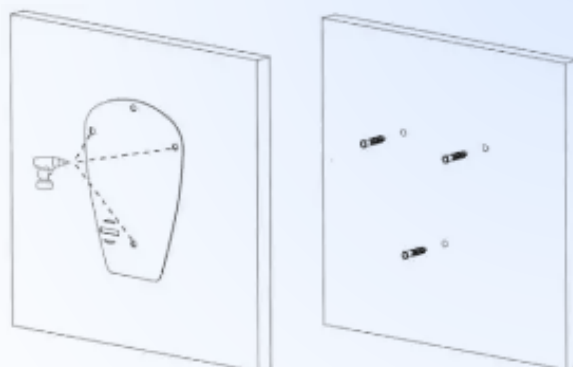

2. Using opening tool (included in the box) remove the black front cover, then unscrew the gray panel.

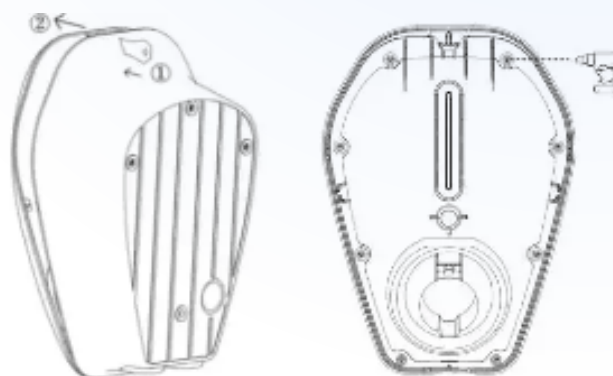

3. Unclip the communication cable and put the front panel aside to protect the cover during installation.



- Remove rubber plugs, fix the device on the wall with screws, and then replace rubber plugs.

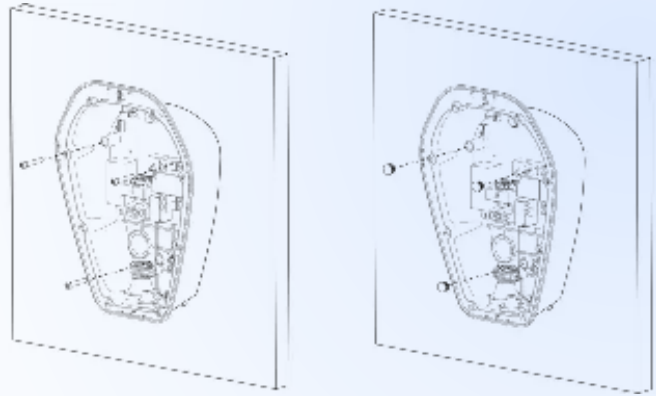

- Connect the cables through the bottom of the junction box.

Tighten the terminal with a torque of 1.2 Nm. Do not over-tighten.

For cable clamp, tighten the screws with a torque of 0.5-0.7 Nm. The bottom cable clamp is removable if required.

Ferrule crimps must be used to ensure warranty is valid

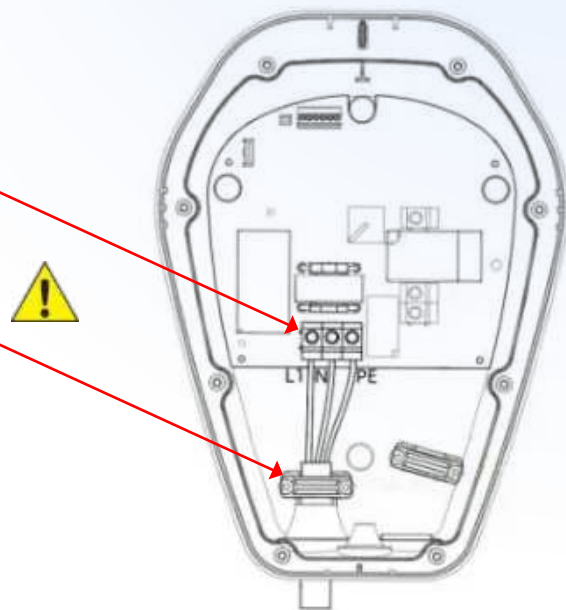

- Dip Switch**

The Dip Switch located on the PCB behind the front panel can be used to set a hard current limit on the charger. A switch in the up position is OFF, while a down position is ON.

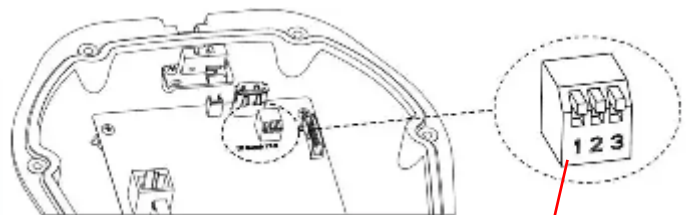

Dip 1	Dip 1	Dip 1	Current Limit
OFF	OFF	OFF	32 A
OFF	OFF	ON	25 A
OFF	ON	OFF	20 A
OFF	ON	ON	16 A
ON	OFF	OFF	10 A



CT CLAMP INSTALLATION

CT Clamps need to be installed on the grid side of the main switch board.

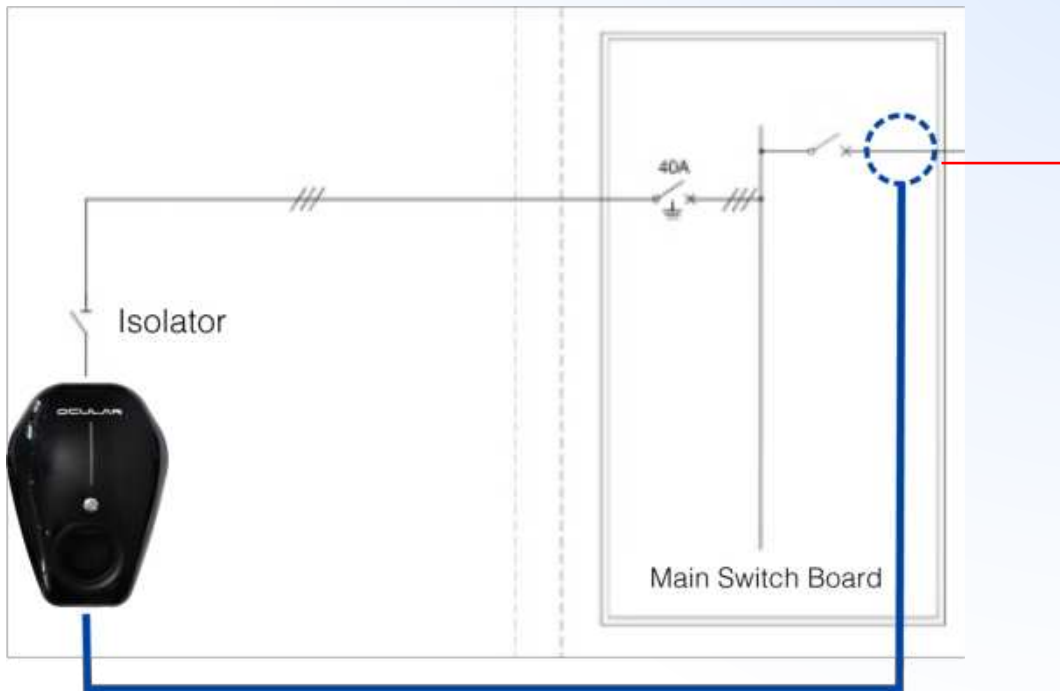

Note:

The CT Clamp cable is 20 meters long.
The Charger must be installed within 20 meters of the incoming supply.



Critical Installation Note:

The CT Clamps have a direction requirement. The Clamps need to be installed so that the arrows are pointing towards the main switch board, i.e. Away from the grid.

Failure to correctly install the CT clamps will require a return to site.

SINGLE PHASE CT INSTALLATION

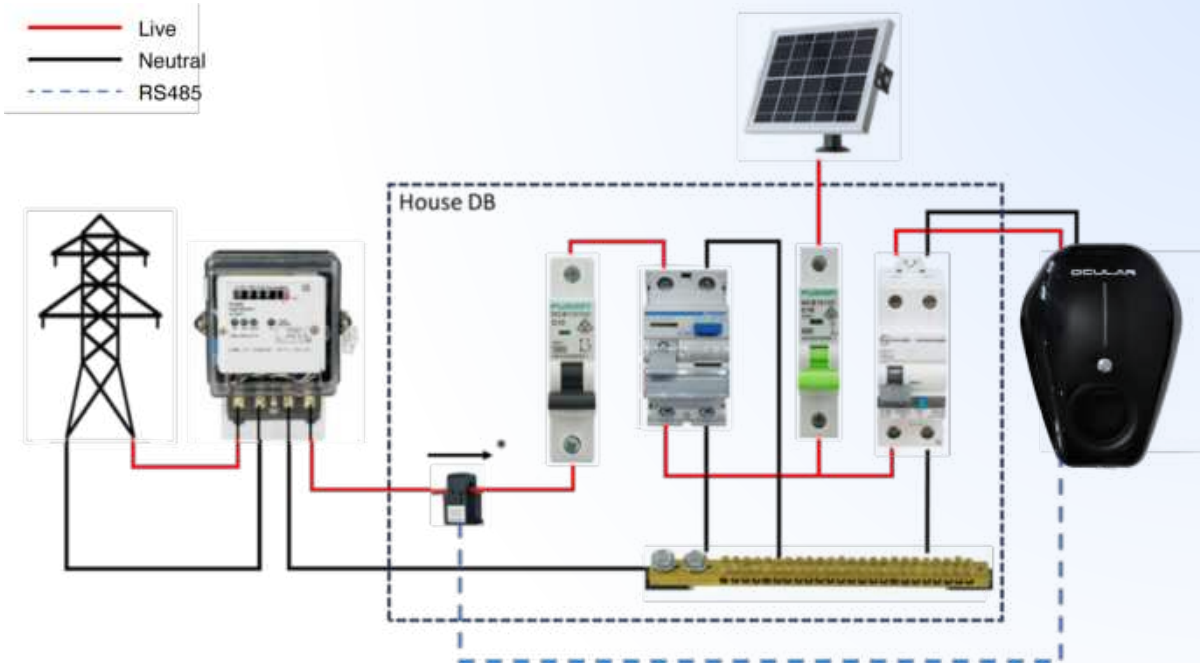

The arrow on the CT must be pointing towards the Main Board and away from the grid supply

THREE PHASE CT INSTALLATION

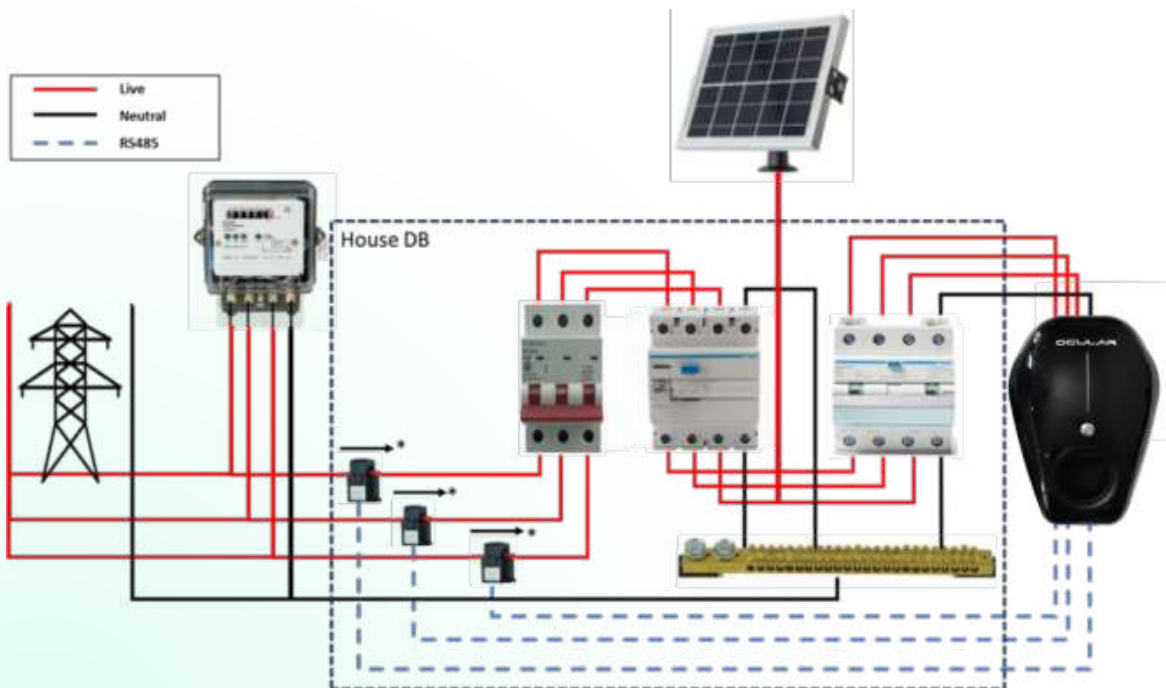

The arrow on the CT must be pointing towards the Main Board and away from the grid supply

CT CLAMP INSTALLATION AND WIRING

Run the CT clamp wires through the grey gland/hole located at the bottom of the charger. Wire into terminal block as indicated in the picture below.

For Single Phase, use the first two ports on the right.



For CTs



Single Phase

Terminal Block



Three Phase

INTERNET CONNECTION AND CHARGER INSTALLATION

1. Connect the charger to the internet

The charger can be connected via ethernet or WIFI. Ethernet is recommended for stability.

Connect the ethernet cable to the WAN port behind the front panel.



WAN Port

2. Reconnect the communication cable to the PCB on the front panel, tighten the screws to secure the front panel.



Tighten the screws with a torque of 0.2-0.5 Nm. Do not over-tighten.

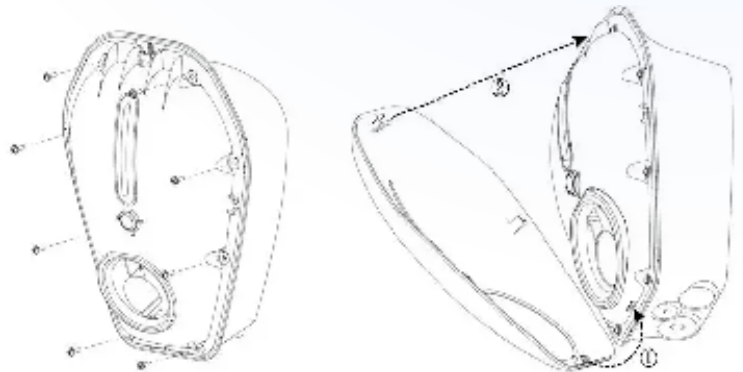

WI-FI

Wi-Fi setup will be shown later in the next page. It is not recommended in commercial installations or apartments. Unstable/weak WI-FI connection may cause undesired operational issues.

WEB-INTERFACE ACCESS AND WIFI CONNECTION

1. Find the chargers' local hotspot using laptop or smart device.

Search for the charger's hotspot like you would for any Wi-Fi network. This hotspot will have the following SSID: **AP_IOC- ******* (if needed you can find the full SSID on the sticker side of the charger)

The password for this Hotspot is: **IOC12345**

2. Navigate to the web-interface of the Ocular Charger.

Open a web browser (Chrome, Safari, Edge) and search: **192.168.10.1:8900**
The web interface will ask for Username and Password:

Username : **install**

Password : **Evcharging123**

After entering the username and password, the Ocular web-interface will load.

3. (Optional): Set up WIFI configuration (not needed if ethernet is used)

- Navigate to the Network tab (see picture on below).
- Click the "Scan" button to start scanning for available WiFi network.
- Use the dropdown list to select the required network, enter the password.
- Click **Submit** then **Reboot** (top right-hand corner) to apply changes.
- You will then need to log back in to the web-interface to continue configuration.

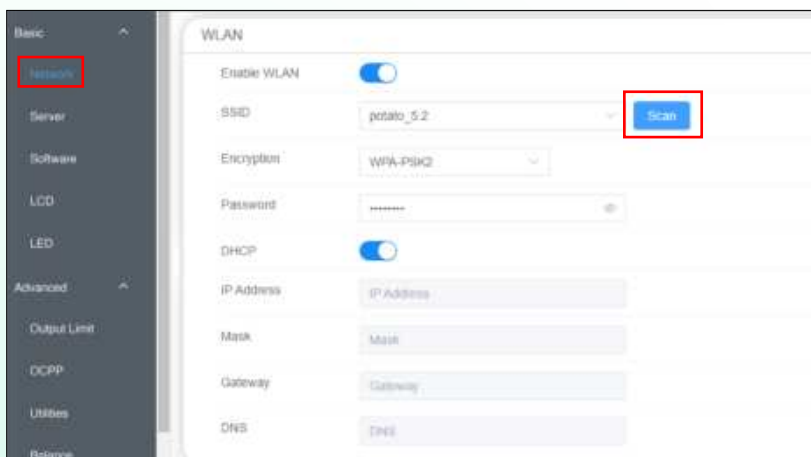

Note: The interface may look different on a smart phone, but all the settings required are the same.

CHARGER CONFIGURATION - ACCESSING THE ADVANCED SETTINGS

Do not change settings other than outlined below as this may affect operations.

1. Log in to the web-interface of the charger. (Refer to page 13).
2. Click on the Balance tab, and then click on “Advanced Settings”.
3. A new page will open that shows the Balance and CT clamp settings.

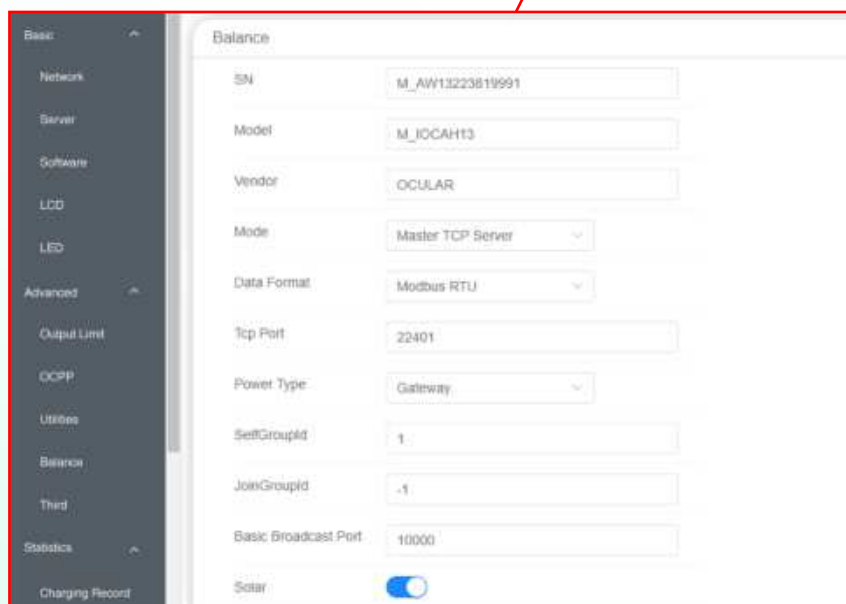
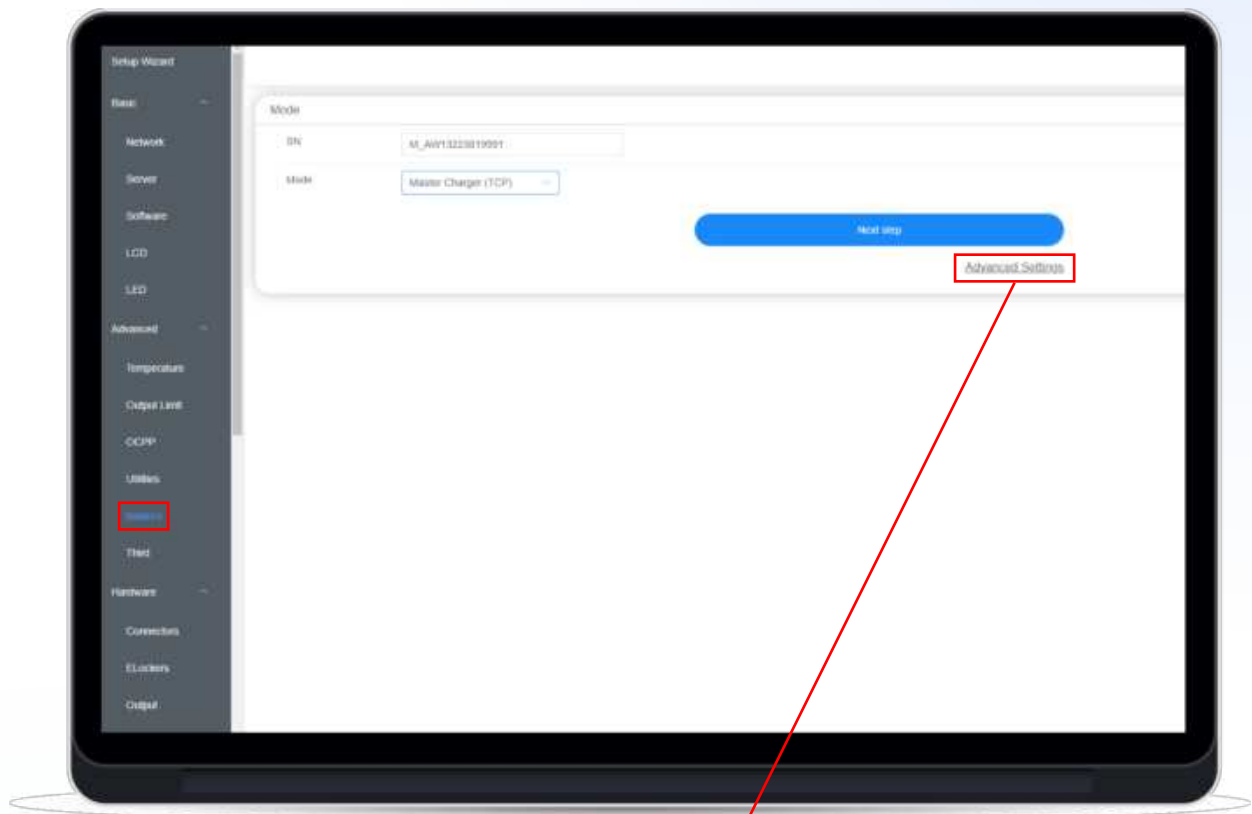

CHARGER CONFIGURATION - CT CLAMP SET UP

1. Scroll down the page until you can see the settings boxes for HUB1 and Grid Current.
2. Ensure HUB1 is switched on (Blue indicator).
3. Configure HUB1 settings as in the pictures below. Note the differences between the Single Phase and 3 Phase setups.
 - A. Single Phase** - Turn off the 3-Phase switch, set CT1 position to “Main”, ensure ratio is set to 2000:1 and set Phase to “L1”.
 - B. Three Phase** - Turn on the 3-Phase switch, set CT1 position to “Main”, ensure ratio is set to 2000:1 and set Phase to “L1”.

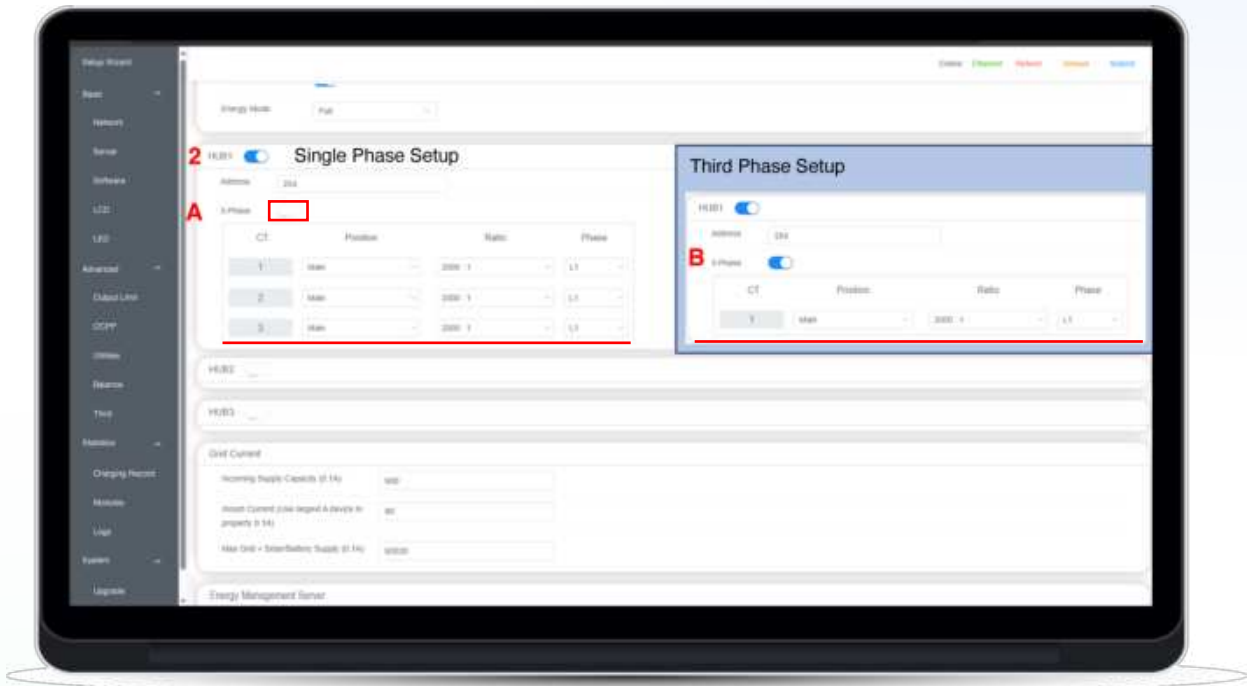

CHARGER CONFIGURATION - GRID SUPPLY SET UP

1. Set the Rated Current and Safe Current.

Rated Current: This is the maximum current that the main MCB can handle.

Safe Current: This is the safe current reserved to prevent the circuit from overloading. The actual available current for the charger is:

$$\text{Actual available current} = \text{rated current} - \text{safe current} - \text{load current}$$

2. In the top right hand corner of the screen, click “Submit” and then “Reboot”.

3. The charger will reboot and then can be used.

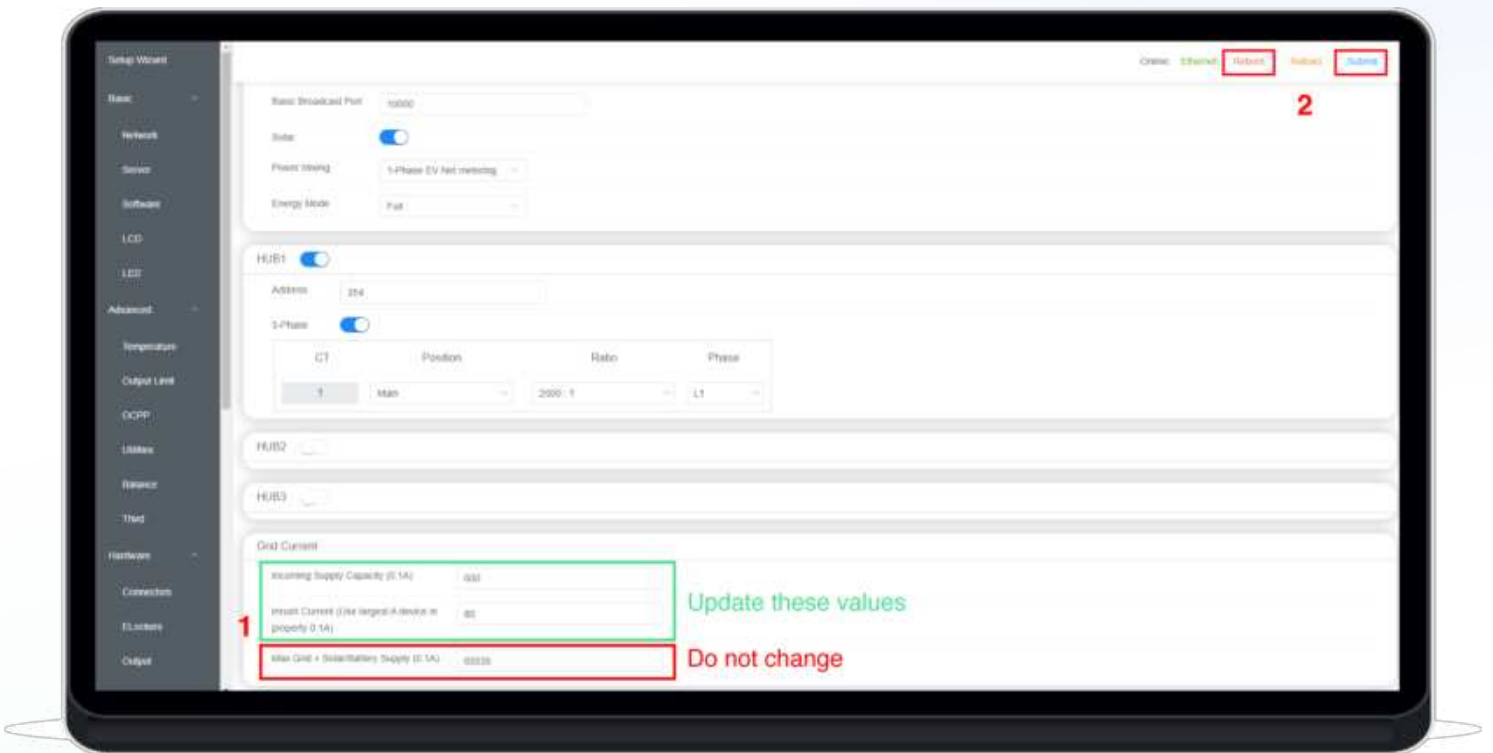

Example

A 80Amp Main Switch Board should have:

Rated Current – 800

Safe Current – 80 (10% safety is recommended as a minimum. This can be higher if required. The charger will stop charging completely if it sees load above 720 which is 72 Amps.)

Please note, the scale is 0.1A i.e. 1 Amp is a value of 10

INSTALLATION VERIFICATION

1. Verify all cabling is wired properly.
2. Verify that the CT clamps are installed in the correct direction.
3. Take a photo of the CT clamp installation at the main board as a record. This will help any future troubleshooting.
4. Turn on the charger and the LED lights should sequentially illuminate blue.
5. If the LED flashes red please refer to the Troubleshooting page.
6. Show customer how to set up the Q1 Solar App (See next page).
7. Test charging with simulator or electric vehicle.

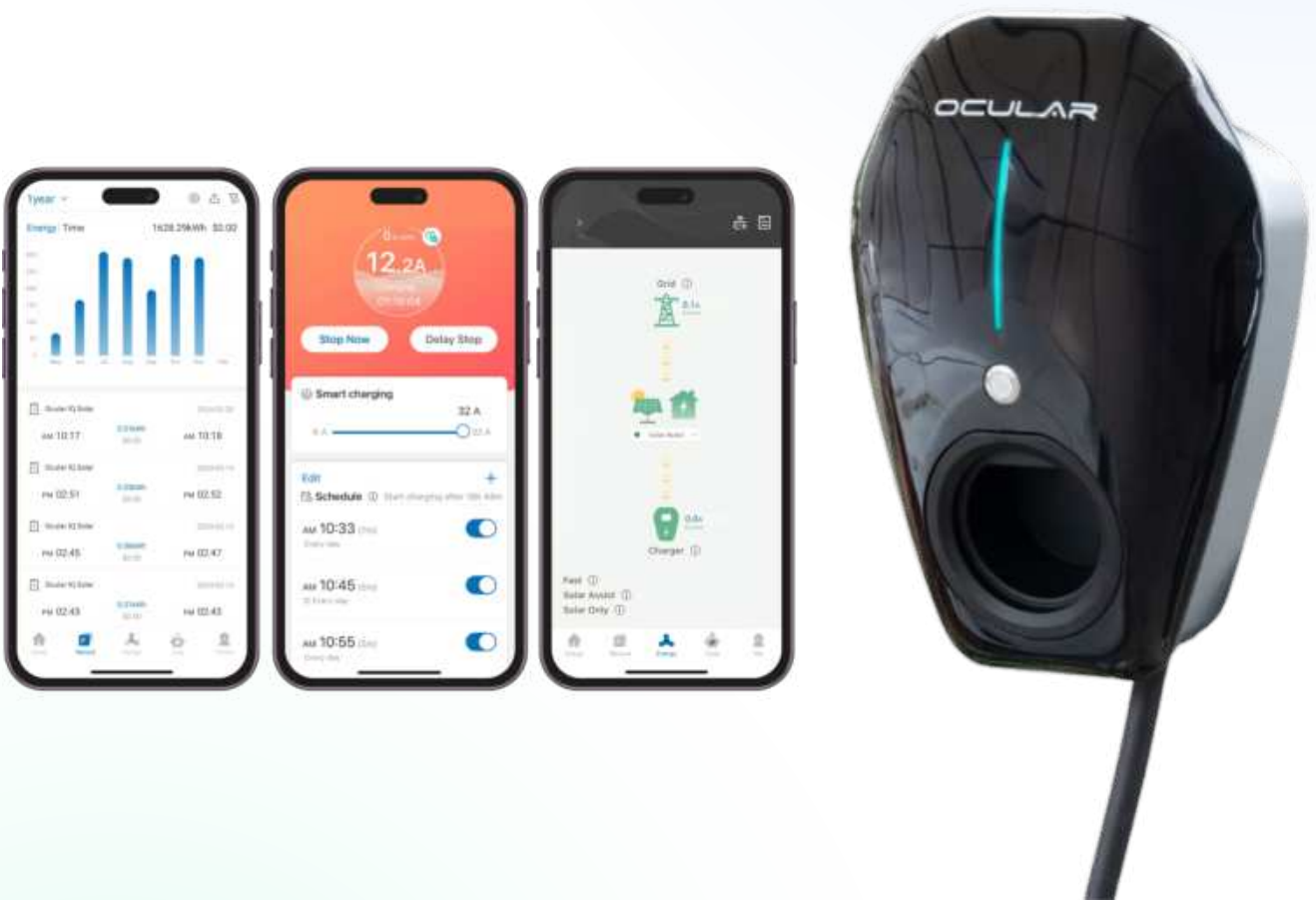

CONNECT CHARGER TO OCULAR SMART HOME APP

1. Search “Ocular Smart Home” or Ocular Charging” on the google play or apple app store.
2. Download, install, and launch the app.
3. Navigate to the Group page and click “Add Station”.
4. Enter the charger serial number. This can be found on a sticker on the side of the charger. It starts with AW and will look like AW1234567890.
5. Click “Add”. The charger should now show up in the group page.
6. Navigate to the “Energy” tab.
7. Enter the gateway serial number. This is the same as the charger serial number but with M_ in front of it. It will look like M_AW1234567890.
8. Click “Add” The energy tab should now show your solar and charger activity.
9. The charger can now be used.

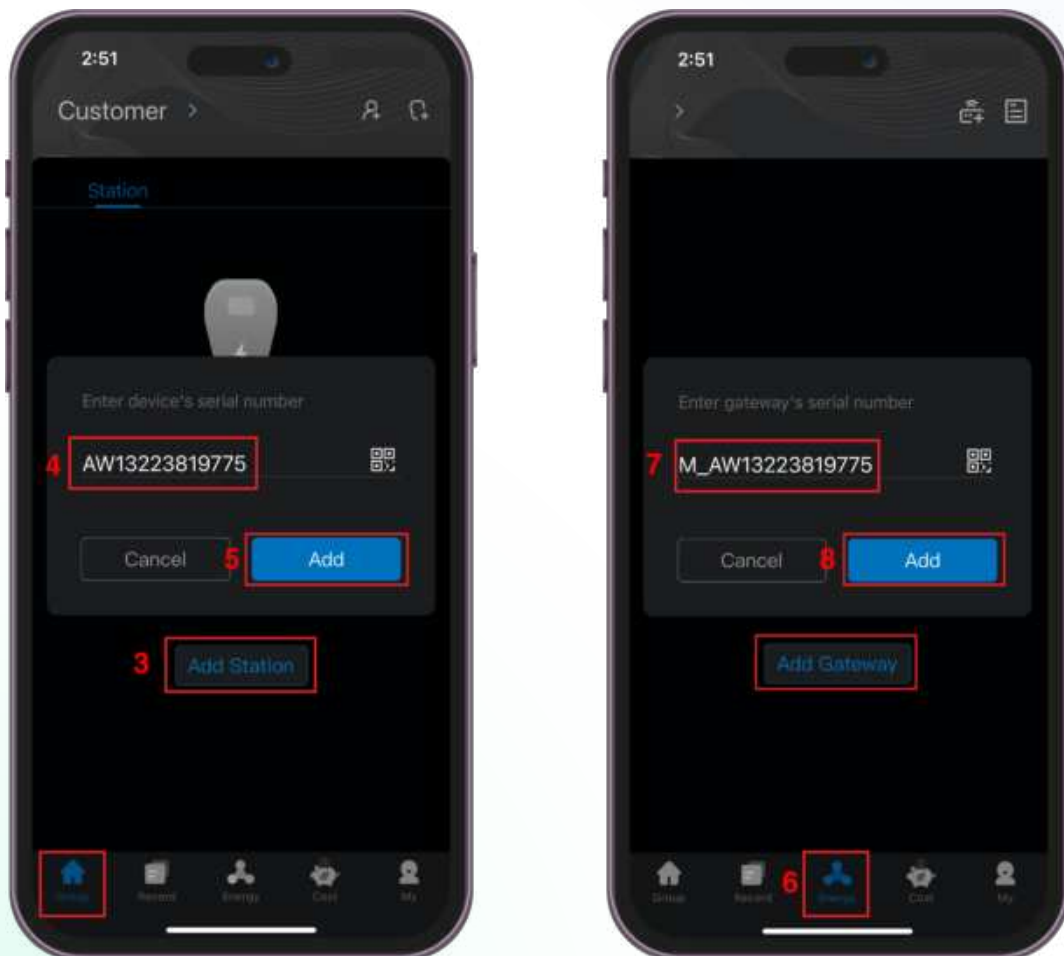







APPENDIX A - TROUBLESHOOTING

Situations		Actions
Status indicator is not blue after the charger is powered on	1	Make sure the AC power input is connected correctly.
	2	Turn OFF the charger and then back ON using the switch.
	3	If the problem persists, contact your installer for Technical Support.
Status indicator does not flash blue when the charger is connected to the EV	1	Unplug the charging plug and reconnect it fully to the receptacle on the EV.
	2	Inspect the cable and plug for damage.
	3	Inspect the EV and its receptacle for damage.
	4	If the situation persists, contact your installer for Technical Support.
Status indicator flashes red while charging	1	There is a temporary error.
	2	Wait until the temporary error is resolved and the charger returns to normal condition. It usually takes less than 10 seconds.
	3	If the status indicator doesn't return to blue, turn OFF the charger and then back ON.
	4	If the situation persists, contact Ocular Charging for Technical Support.
Status indicator is solid red	1	There is a critical error.
	2	Unplug the charging plug from the EV immediately.
	3	Turn OFF the charger and then back ON.
	4	If the situation persists, contact your installer for Technical Support.

APPENDIX B – CHARGER ERROR CODES

This page shows the error codes' meaning, if any of the charger presents any error listed below, please contact your installer for technical support.

LED Diagram	LED Status	Definition
	Red light is solid	CP / CC fault
	Alternately flashing red and green	Overcurrent / Overvoltage / Undervoltage
	Alternately flashing red and blue	e-locker / relay fault
	Group A and B, red and red flashing alternately	PE fault
	Group A and B, red and green flashing alternately	RCD fault
	Group A and B, red and blue flashing alternately	PME fault
	Flashing red	Other fault

APPENDIX C – CT CLAMP SPECIFICATIONS

Prior to setting up the CT clamps, please ensure that you have the correct CT and CT Ratio setup. Only use CT clamps provided by Ocular - The wrong CT clamps will cause a misreading and void warranty. If you must use your own CT, please speak to Ocular and confirm suitability. The Rate Transformation Ratio **must be 2000:1 or the CT clamps will generate incorrect readings.**

Situations		Actions
Rated Current Ratio		100A:50mA
TYPE		IOCCT100
Electrical Specifications		
Rated Primary Current (A)	100A	
Secondary Current (mA)	50mA	
Maximum Current I _{max} (A)	120A	
Rate Transformation Ratio	2000:1	
Power-Frequency Withstand Voltage	4000 V _{rms}	
Current Error	±0.5%	
Rated Phase Displacement	≤80°	
Rated Frequency	50/60Hz	
Rated Short-Time Thermal Current	400A (≤1s)	
Rated Resistive Burden (Ω)	≤ 20Ω	
Insulation Resistance (MΩ)	>500MΩ	
Mechanical Specifications		
Encapsulant	Epoxy Resin	
Weight (g)	110g	
Tolerance (mm)	±1.5	
Storage Temperature (°C)	-40°C < T < +85°C	
Working Temperature (°C)	-25°C < T < +75°C	
Working Humidity	0-90% (no condensation)	
Enclosure Flame Retardant Grade	UL94 V-0	

OCULAR

IQ HOME SOLAR

ocularcharging.com.au
sales@ocularcharging.com.au
1300 912 650