



OCULAR



# IQ HOME SOLAR INSTALLATION GUIDE

IOCAH30-7TE-RW  
IOCAH30-22TE-RW

Version 2.0

 [ocularcharging.com.au](https://ocularcharging.com.au)  
 [sales@ocularcharging.com.au](mailto:sales@ocularcharging.com.au)  
 1300 912 650

# CONTENTS

---

Specifications.....	3
Product Overview.....	4
Safety Instruction.....	5
Installation Notes and Box Contents.....	6
Wall Mounting.....	7
CT Clamp Installation.....	9
Single Phase CT Installation Diagram.....	10
Three Phase CT Installation Diagram.....	10
CT Clamp Wiring.....	11
Internet Connection and Charger Installation.....	12
Web-Interface Access and WIFI Setup.....	14
Charger Configuration - Accessing Charger Settings.....	16
Charger Configuration - CT Clamp Set Up.....	17
Charger Configuration - Grid Supply Set Up.....	18
Connect Charger to Ocular Smart Home App.....	19
Appendix A - Troubleshooting.....	20
Appendix B - Charger Error Codes.....	21
Appendix C - CT Clamp Specifications.....	22
Appendix D - Change the Charger to 'Start Charging On Plug'.....	23

## IMPORTANT!

Read this entire document before installing or using the charger. Failure to do so or to follow any of the instructions and warnings in this document can result in fire, electrical shock, serious injury, or death.

The charger must be installed by a qualified electrician.

The entire installation must comply with the latest AS/NZS 3000:2018 standards.

## SPECIFICATIONS

Model Number	IOCAH30-7TE-RW	IOCAH30-22TE-RW
Power		
Power Output	7.2kW (1-Phase)	22kW (3-Phase)
EV Charging Connector	5m Type-2 Cable	
Input and Output Voltage	230V $\pm$ 20%	400V $\pm$ 20%
Input and Output Current	32A max per phase	
Recommended Circuit Breaker	40A type A RCBO	
Frequency (Hz)	50/60Hz	
Current Transformers (CT) for Solar and Load Control		
CTs Included	1	3
CT Length of Signal Line	20m (Extendable up to 100m with insulated twisted pair cable)	
CT Primary Rated Current	100A max current	
CT Internal Diameter	16mm (fits max cable size 50mm <sup>2</sup> XLPE)	
User Interaction		
Display	LED indication lights	
RFID Reader	ISO14443 Type A cards compatible	
Charger Control Method	Mobile App, physical button, RFID, plug and charge	
Safety		
Internal RCD	RDC-DD 30mA & 6mA DC Leakage	
Electrical Protection	Over current, Short circuit, Over voltage, Under voltage, Ground fault, Lightning surge, Over temperature	
Communication		
OCPD	1.6J and 2.0.1 (Firmware upgrade required)	
Internet Connection	Ethernet, Wi-Fi, 4G (4G version only)	
Communication Type	Modbus (TCP/IP)	
Energy Meter	Integrated Meter	
Load Control	Compatible with Ocular Load Controller or OCPP smart profiles	
General Data		
Ambient Air Temperature for Operation	-30 to +50	
Ambient Air Temperature for Storage	-40 to +70	
Working Humidity	5% - 95% relative humidity, non-condensing	
IP Performance	IP55	
Mounting	Wall Mount	
Dimension (H x W x D, mm)	398 * 285 * 226 mm	
Net Weight	4.5 kg	4.7 kg
Certification	CE, IEC /EN 61851-1, IEC 61008-1-A1, IEC 62955-1-A1, IEC/EN 61851-21-2, IEC 62196-2, RCM	
Warranty	2 Years (Extended warranties available)	

## PRODUCT OVERVIEW

---



No	Item
1	Type-2 charging cable and plug
2	LED status indicator
3	RFID
4	Physical button
5	Plug storage recess

## SAFETY INSTRUCTION

---

This document contains important instructions and warnings that must be followed when installing and maintaining the Ocular IQ Home Solar.

### WARNINGS

Installation and maintenance of the charger should only be conducted by a qualified and licensed electrician.

Make sure that materials used, and installation procedures follow local building codes and safety standards, including AS/NZS 3000:2018.

Do not install or use the charger near flammable, explosive, harsh, or combustible materials, chemicals, or vapours.

Always deenergise and isolate the unit before installation, opening the unit, or performing maintenance from the circuit breaker or isolator.

Do not attempt to open, disassemble, repair, tamper with, or modify the charger unless you are a licensed electrician. The unit is not user serviceable.

Do not use the charger if it appears defective, cracked, frayed, broken, damaged, or fails to operate.

Do not use this charger if the EV charging cable is frayed, has broken insulation, or shows any other indication of damage.

Do not use this charger if the enclosure or EV charging connector is cracked, open, or shows any indication of damage.

Do not touch the charger sockets with sharp metallic objects, such as wire, tools, or needles, and do not put fingers into the sockets.

Incorrect installation and usage of the charger could potentially damage the vehicle's battery and/or the charger itself, voiding the warranty for both.

Do not operate the charger in temperatures outside its range of -30°C to +50°C.

Ensure that the EV charging cable is positioned properly in the charging sockets. Do not use cleaning solvents on any charger components.

## NOTES BEFORE INSTALLATION

---

The charger should be protected by an external Residual Current Device (RCD) to be installed in the upstream circuit which complies with the following:

- Type-A Rated residual operating current not exceeding 30 mA
- Required as per Appendix P, AS/NZS 3000:2018 Australia Standard for EV charging stations.

Recommended (Note installation requirements are site specific and may vary):

- 40A 30mA Type A RCBO
- Isolation Switch close to the charger
- 10mm<sup>2</sup> 2C (or 4C) + E Cabling

## TOOLS REQUIRED

---

- Philips #1 screwdriver
- Philips #2 screwdriver
- 2.5 mm flat blade terminal screwdriver
- Electric drill
- EV charger testing (Metrel 3152)
- Laptop or mobile device
- Ferrule crimping tool

## BOX CONTENTS

---



- CT clamps
- 1 clamp
  - 3 clamp

**Please note:** The provided CT clamp cable is 20 meters long. Charger must be placed within 20m of the incoming supply. Fits 16mm diameter cabling up to 100A max current.

If the incoming supply is longer than 20 meters, we recommend using an insulated twisted pair cable (E.g. Cat5) with soldering tools for the extension.

## WALL MOUNTING AND WIRING

---

1. Use the enclosed template to mark and drill the mounting holes. Only three screws are required during wall mounting. Using the top screw hole is not required.

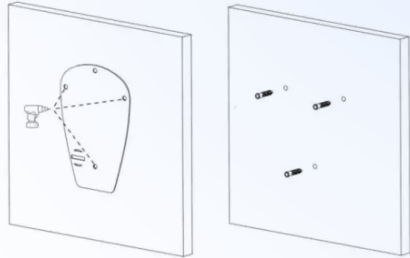

2. Using opening tool (included in the box) remove the black front cover, then unscrew the gray panel.

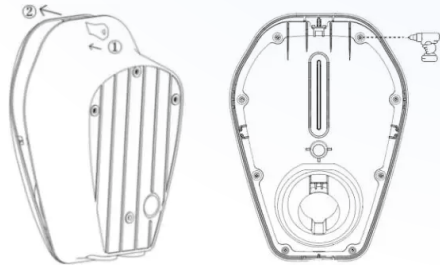

3. Unclip the communication cable and put the front panel aside to protect the cover during installation.



- Remove rubber plugs, fix the device on the wall with screws, and then replace rubber plugs.

It is critical that the rubber plugs get replaced otherwise the IP rating of the charger will be impacted.

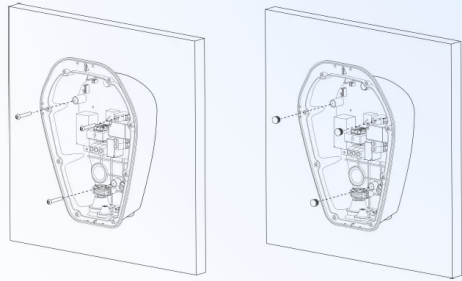

- Connect the cables into the terminal block.

Tighten the terminal with a torque of 1.2 Nm. Do not over-tighten.

For cable clamp, tighten the screws with a torque of 0.5-0.7 Nm. The bottom cable clamp is removable if required.

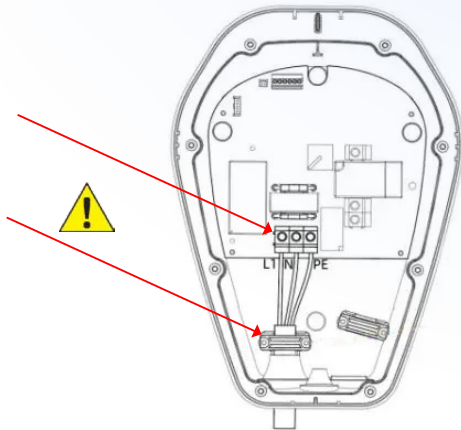

- The Dip Switch located on the PCB behind the front panel can be used to set a hard current limit on the charger. A switch in the up position is OFF, while a down position is ON.

Inform the customer that the charger has been set with a hard limit and make a note in this user manual.

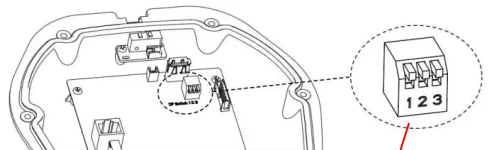

Dip 1	Dip 2	Dip 3	Current Limit
OFF	OFF	OFF	32 A
OFF	OFF	ON	25 A
OFF	ON	OFF	20 A
OFF	ON	ON	16 A
ON	OFF	OFF	10 A

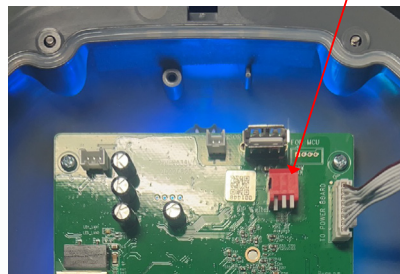



## CT CLAMP INSTALLATION

CT Clamps need to be installed on the grid side of the main switch board.

CT Clamp cables can present an electric shock when the Clamps have been installed but not wired into the charger. To reduce the risk of electric shock, wire the CT clamps into the charger terminal block (Shown on page 11), before installing the CT clamps on the incoming supply.

If it is easier to route the CT cable without it connected to the CT clamp, you can cut the CT cable and then resolder the connections.

If extension of the CT cables is needed beyond the included 20 meters, twisted-pair cable like CAT5 must be used. Do not use straight wire. To join the CT cables, make sure the ends are twisted tightly and joined using a soldered connection.

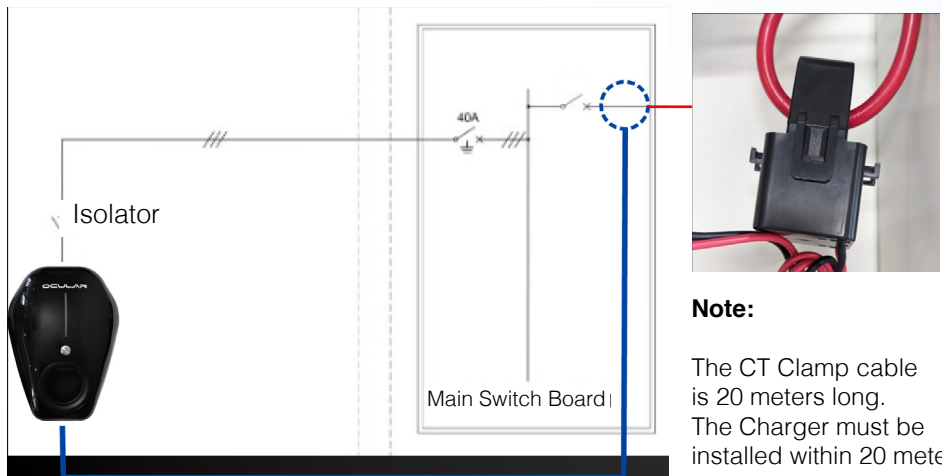

### Critical Installation Note:

The CT Clamps have a direction requirement. The Clamps need to be installed so that the arrows are pointing towards the main switch board, i.e. Away from the grid.

Failure to correctly install the CT clamps will require a return to site.

# SINGLE PHASE CT INSTALLATION

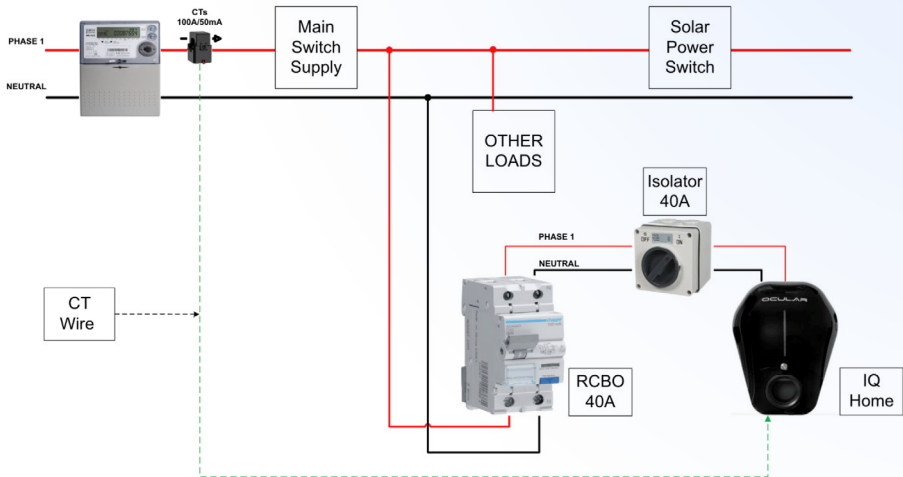

The arrow on the CT must be pointing towards the Main Board and away from the grid supply

# THREE PHASE CT INSTALLATION

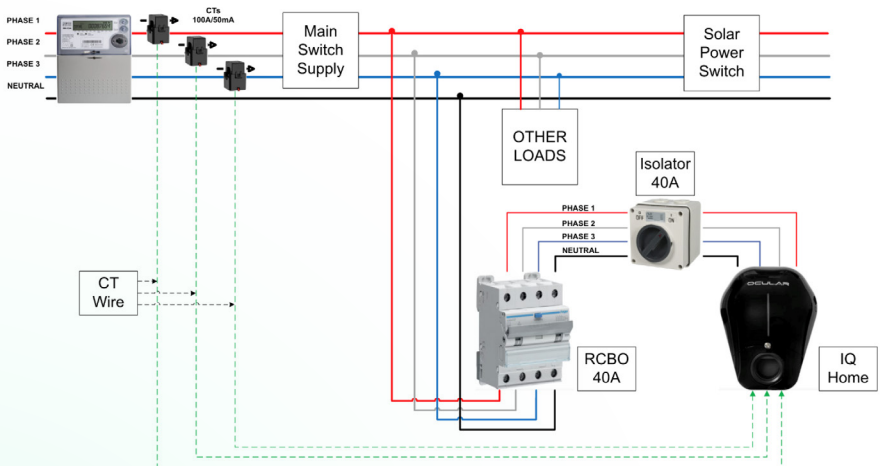

The arrow on the CT must be pointing towards the Main Board and away from the grid supply

## CT CLAMP INSTALLATION AND WIRING

Run the CT clamp wires through the grey gland/hole located at the bottom of the charger. Wire into terminal block as indicated in the picture below.

For Single Phase, use the first two ports on the right.

**N = Black, P = Red**

For Three Phase, the order is reversed as per the picture below.



For CTs and Ethernet cable

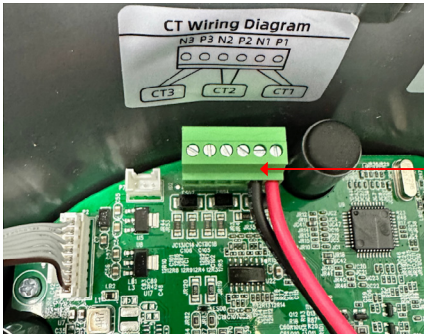

Single Phase

Terminal Block



Three Phase

## INTERNET CONNECTION AND CHARGER INSTALLATION

The charger must be successfully connected to the internet during the installation process to ensure proper operation. There are three options for internet connectivity:

- Ethernet (recommended for maximum internet stability)
- WiFi
- 4G (4G capable units only)

Connect the ethernet cable to the WAN port behind the front panel. This ethernet cable can be run through the same gland as the CT clamp wires.

4G capable units will have a SIM card slot that can take a Nano Sized Sim card. To use 4G, Insert the SIM card into the SIM card slot. Confirm that the SIM card is fully seated. Configuration of the SIM card details will be completed at a later stage.

After the charger has been mounted, connected to incoming power and ethernet or 4G has been connected, the unit can be closed. WiFi connection can be done after the charger has been energised.

Reconnect the communication cable to the PCB on the front panel, tighten the screws to secure the front panel.



Tighten the screws with a torque of 0.2-0.5 Nm.  
Do not over-tighten.

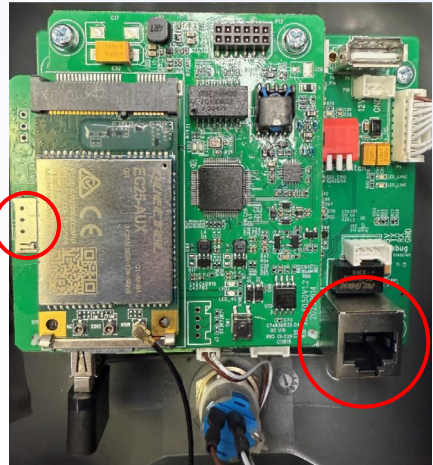

Sim Card and WAN Port

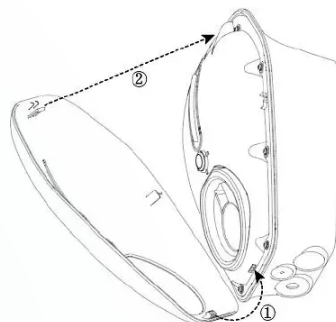
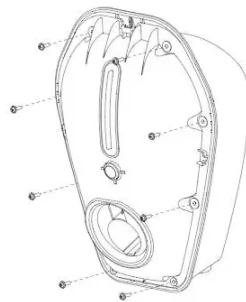

## SET UP / PROCESS

---

### 1. Pre-energising

- Ensure connections are secure and power on the system.
- Verify all cabling is wired properly.
- Verify that the CT clamps are installed in the correct direction.
- Take a photo of the CT clamp installation (clearly showing the arrows on CT clamp) on the main board as a record. This will help any future troubleshooting.
- Energise the charger.
- LED lights should sequentially illuminate blue.
- If the LED flashes red please refer to the Troubleshooting page.

### 2. Post-energising

- Use an EV charger tester (e.g Metrel, Fluke) to run testing following AS/NZS 3000 Section 8.3.3.1.
- If the charger does not begin to charge under testing with the EV Tester, it may not be configured to 'start charging on plug', please refer to Appendix F how to set it as 'start charging on plug'.
- Test functionality and perform safety inspection.

# WEB-INTERFACE ACCESS AND WIFI CONNECTION

## 1. Find the chargers' local hotspot using laptop or smart device.

Search for the charger's hotspot like you would for any Wi-Fi network. This hotspot will have the following SSID: **AP\_IOC- \*\*\*\*\*** (if needed you can find the full SSID on the sticker side of the charger)

The password for this Hotspot is: **IOC12345**

## 2. Navigate to the web-interface of the Ocular Charger.

Open a web browser (Chrome, Safari, Edge) and search: **192.168.10.1:8900**  
The web interface will ask for Username and Password:

The login information will be: Username : **install**  
Password : **installer123**

You will be asked to change it to a new password.

We recommend 'Evcharging123'

Write the new login password here: \_\_\_\_\_.

Please hand this book to the user after the installation so that they can keep track of the new password.

## 3. (Optional): Set up WIFI configuration (not needed if ethernet is used)

- Navigate to the Network tab (see picture below).
- Click the "Scan" button to start scanning for available WiFi network.
- Use the dropdown list to select the required network, enter the password.
- Click **Submit** then **Reboot** (top right-hand corner) to apply changes.
- You will then need to log back in to the web-interface to continue configuration.

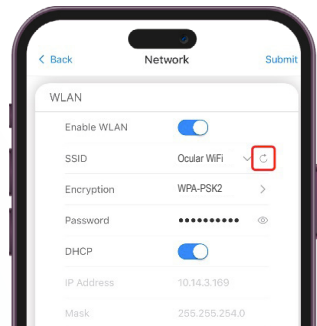
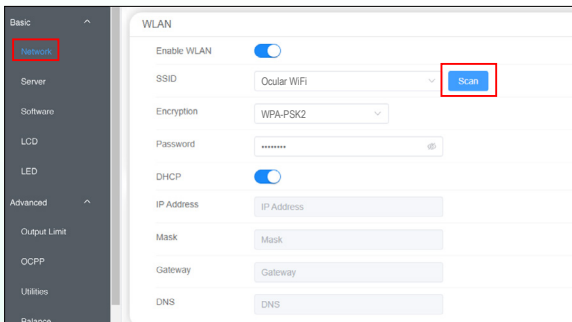

#### 4. Set up 4G Connection (4G enabled version only)

- Confirm that a SIM card was inserted during the installation step.
- Navigate to the network and then navigate to the 4G section
- Toggle the Enable 4G switch
- Enter the SIM card details including APN, Dial, pin code, user, and password.
- Click Submit then Reboot (top right-hand corner, or on the home page) to apply changes.
- Contact your sim card provider for these details or if there are connectivity issues.

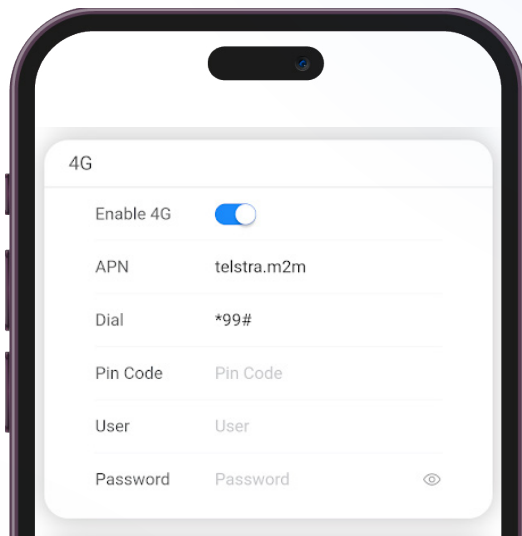

# CHARGER CONFIGURATION - ACCESSING THE ADVANCED SETTINGS PAGE

**Do not change settings other than outlined below as this may affect operations.**

1. Log in to the web-interface of the charger. (Refer to page 14).
2. Click on the Balance tab, and then click on "Advanced Settings".
3. A new page will open that shows the Balance and CT clamp settings.

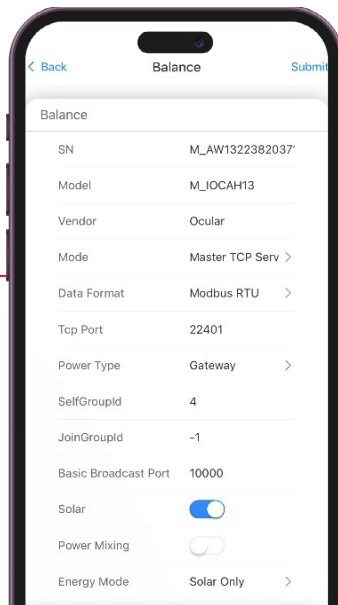
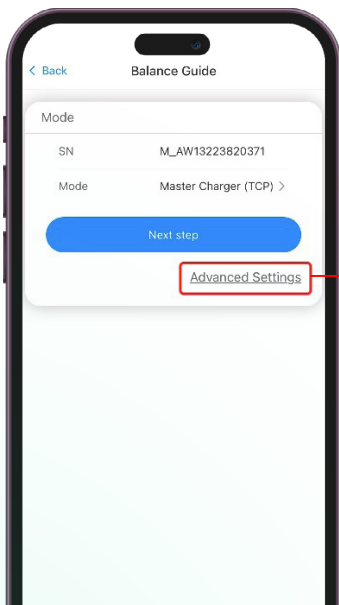
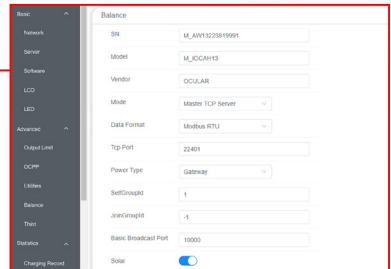
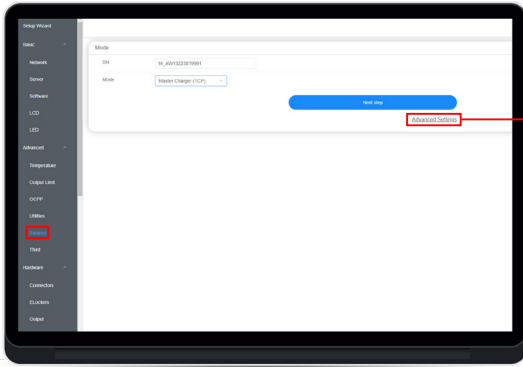



# CHARGER CONFIGURATION - CT CLAMP SET UP

1. Scroll down the page until you can see the settings boxes for HUB1 and Grid Current.
2. Ensure HUB1 is toggled on (Blue indicator).
3. Configure HUB1 settings as in the pictures below. Note the differences between the Single Phase and Three Phase setups.
  - A. Single Phase** - Toggle off the 3-phase button, set CT1 position to “Main”, ensure ratio is set to 2000:1 and set Phase to “L1”.
  - B. Three Phase** - Toggle on the 3-phase button, set CT1 position to “Main”, ensure ratio is set to 2000:1 and set Phase to “L1”.

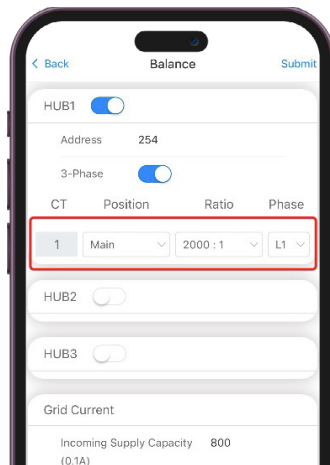
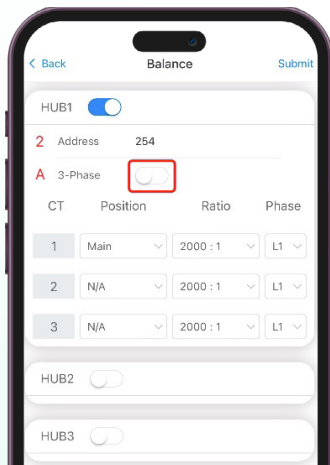
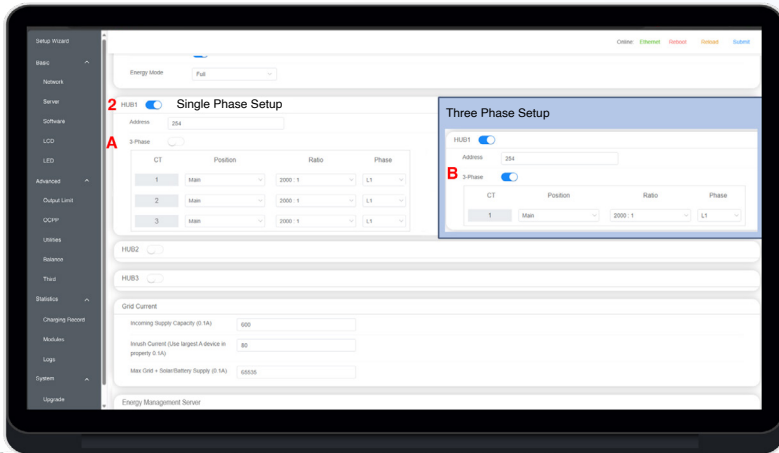

# CHARGER CONFIGURATION - GRID SUPPLY SET UP

1. Set the Incoming Supply Capacity and Inrush Current.

**Incoming Supply Capacity:** This is the maximum current that the main MCB can handle.

**Inrush Current:** This is a safe margin reserved to prevent the circuit from overloading. We recommend setting it to be a minimum of 10% of Incoming Supply Capacity or the largest possible current draw from a device.

The maximum charging speed of the charger is:

**Maximum charging speed = Incoming Supply Capacity - Inrush current - Current from other loads**

2. In the top right hand corner of the screen, click “Submit” and then “Reboot”.
3. The charger will reboot and then can be used.

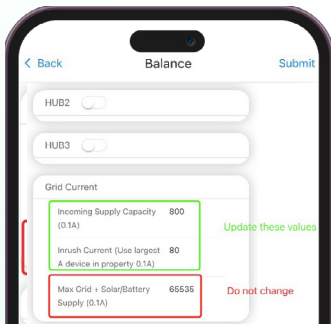
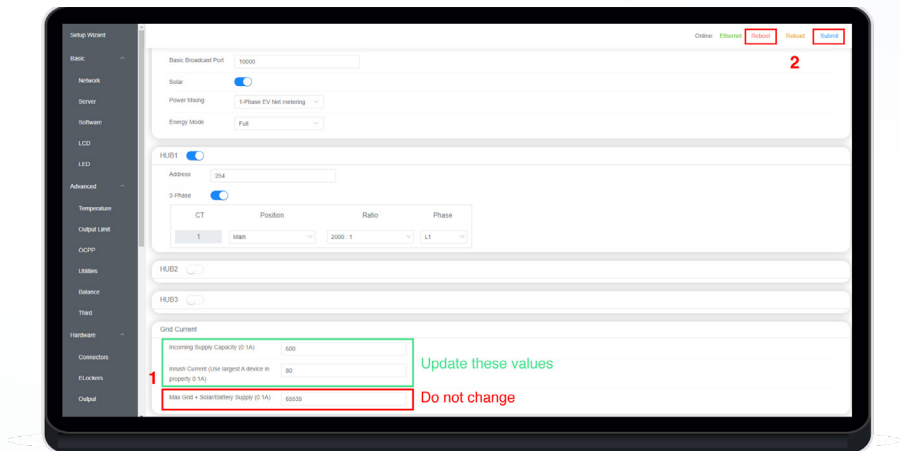

## Example

A 80Amp Main Switch Board should have:

Incoming Supply Capacity - 800

Inrush Current - 80 (10% safety is recommended as a minimum. This can be higher if required. The charger will stop charging completely if it sees load above 720 which is 72 Amps.)

\*Please note, the scale is 0.1A i.e. 1 Amp is a value of 10\*

## CONNECT CHARGER TO OCULAR SMART HOME APP

1. Search “Ocular Smart Home” or “Ocular Charging” on the google play or apple app store.
2. Download, install, and launch the app.
3. Navigate to the Group page and click “Add Station”.
4. Enter the charger serial number. This can be found on a sticker on the side of the charger. It starts with AW and will look like AW1234567890.
5. Click “Add”. The charger should now show up in the group page.
6. Navigate to the “Energy” tab.
7. Enter the gateway serial number. This is the same as the charger serial number but with M\_ in front of it. It will look like M\_AW1234567890.
8. Click “Add” The energy tab should now show your solar and charger activity.
9. The charger can now be used.

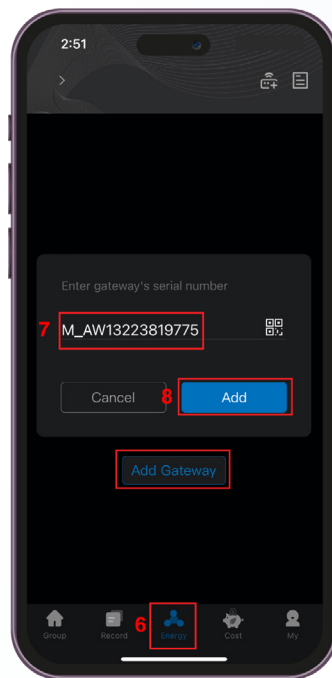
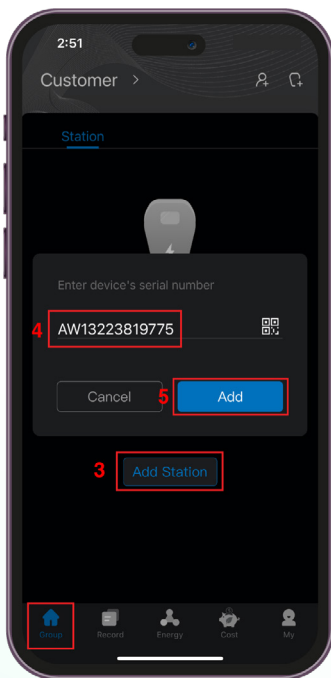

## APPENDIX A - TROUBLESHOOTING

Situations	Actions
<p>Status indicator is not blue after the charger is powered on</p>	<ul style="list-style-type: none"> <li>• Make sure the AC power input is connected correctly.</li> <li>• Turn OFF the charger and then back ON using the isolator switch.</li> <li>• If the problem persists, contact your installer for Technical Support.</li> </ul>
<p>Status indicator does not flash blue when the charger is connected to the EV</p>	<ul style="list-style-type: none"> <li>• Unplug the charging plug and reconnect it fully to the receptacle on the EV.</li> <li>• Inspect the cable and plug for damage.</li> <li>• Inspect the EV and its receptacle for damage.</li> <li>• If the situation persists, contact your installer for Technical Support.</li> </ul>
<p>Status indicator flashes red while charging</p>	<ul style="list-style-type: none"> <li>• There is a temporary error.</li> <li>• Wait until the temporary error is resolved and the charger returns to normal condition. It usually takes less than 10 seconds.</li> <li>• If the status indicator doesn't return to blue, turn OFF the charger and then back ON.</li> <li>• If the situation persists, contact Ocular Charging for Technical Support.</li> </ul>
<p>Status indicator is solid red</p>	<ul style="list-style-type: none"> <li>• There is a critical error.</li> <li>• Unplug the charging plug from the EV immediately.</li> <li>• Turn OFF the charger and then back ON.</li> <li>• If the situation persists, contact your installer for Technical Support.</li> </ul>

## APPENDIX B – CHARGER ERROR CODES

This page shows the error codes' meaning, if any of the charger presents any error listed below, please contact your installer for technical support.

LED Diagram	LED Status	Definition
	Red light is solid	CP / CC fault
	Alternately flashing red and green	Overcurrent / Overvoltage / Undervoltage
	Alternately flashing red and blue	Socket lock / Output relay fault
	Group A and B, red and red flashing alternately	Ground fault
	Group A and B, red and green flashing alternately	RCD fault
	Group A and B, red and blue flashing alternately	PME fault (Phase Imbalance or under / over voltage)
	Flashing red	Other fault

## APPENDIX C – CT CLAMP SPECIFICATIONS

Prior to setting up the CT clamps, please ensure that you have the correct CT and CT Ratio setup. Only use CT clamps provided by Ocular - The wrong CT clamps will cause a misreading and void warranty. If you must use your own CT, please speak to Ocular and confirm suitability. The Rate Transformation Ratio **must be 2000:1 or the CT clamps will generate incorrect readings.**

Description	Current Transformer
Rated Current Ratio	100A:50mA
Type	HCT16K-TYT(E0310)
Electrical Specifications	
Rated Primary Current (A)	100A
Secondary Current (mA)	50mA
Maximum Current I <sub>max</sub> (A)	120A
Rate Transformation Ratio	2000:1
Rated Insulation Level	4000 Vrms/60s
Current Error	±0.5%
Rated Phase Displacement	≤80'
Rated Frequency	50/60Hz
Rated Short-time Thermal Current	400A (≤1s)
Rated Resistive Burden	≤ 20Ω
Insulation Resistance	> 500MΩ
Output Lead Spark Test	2KV In Air
Mechanical Specifications	
Encapsulant	Epoxy resin
Approx. Weight	About 425g
Tolerance(mm)	±1.5
Storage temperature	-40°C<T<+85°C
Working temperature	-25°C<T<+75°C
Working humidity	0-90% (no condensation)
Enclosure flame retardant grade	UL94 V-0

Mechanical dimensions in mm

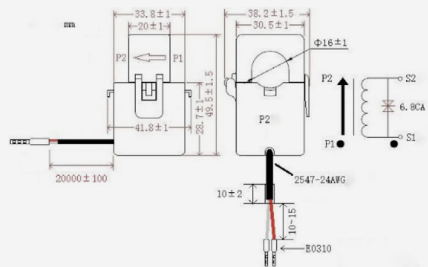

Same polarity: \*--\*

Direction for use

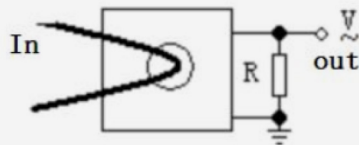

## APPENDIX D – CHANGE THE CHARGER TO ‘START CHARGING ON PLUG’

If the charger does not automatically start charging while testing, then it may not be set to charge on plug. Follow the steps below to change it. The user will be able to change this setting in the Ocular App later.

- Follow the instructions on Page 14 to log into the charger web-interface.
- Navigate to the “Software” Tab under “Basic”
- Under the subsection “Switcher”, tick the box next to “Free Charging on Plug”
- Click submit “Submit” on the top right-hand corner of screen, and then click “restart” on the Home page.

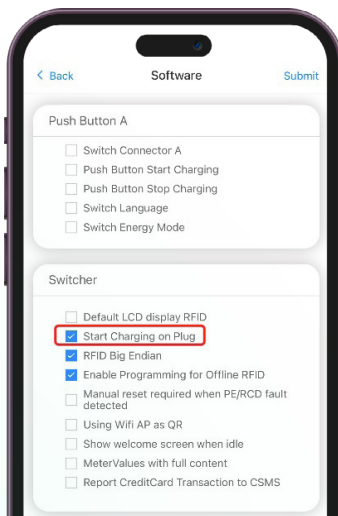
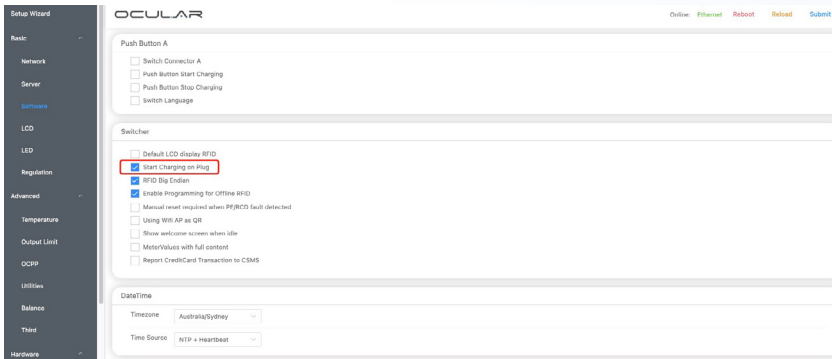

# OCULAR

## IQ HOME SOLAR

[ocularcharging.com.au](http://ocularcharging.com.au)  
[sales@ocularcharging.com.au](mailto:sales@ocularcharging.com.au)  
1300 912 650